



Desiccators and Drying Cabinets

Glove Boxes and Extractor Hoods

- » stable
- » functional
- » custom-made



All information in our catalogue is based on current technical knowledge, experience and manufacturers' data. Users should check the suitability of parts and materials described in the catalogue before use.

BOHLENDER does not accept any warranty as to suitability and fitness of purpose of the materials and products described in this catalogue. Users should avoid making any assumptions on, or interpretations of, the data herein.

All products are subject to technical modification without prior notice.

The following are the registered trademarks of the respective organisations:

Plexiglas® by Evonik Röhm GmbH



NEW

New products are shown with this icon.



BESTSELLER

Our best sellers

Copyright BOHLENDER GmbH, all rights reserved. Copies of this catalogue, in whole or in parts are only permitted with BOHLENDER GmbH's prior written consent.



Dear Customer,

The successful SICCO product range, made by BOHLENDER, has repeatedly been extended.

Our range of desiccators, drying cabinets and glove boxes now offers a larger choice. More than 80 pages full of functional new SICCO products wait to be discovered by you. All new models can be easily identified – they are marked with the sticker “NEW”.

Of course, you can still rely on the high quality of our manufacturing process that ensures long product life and ease of use.

As a manufacturer, we are able to offer an individual custom manufacture if you have a special request. This is easier and faster than you may expect – starting with 1 piece. Just talk to our experts about your ideas, we will be glad to assist you.

As you can see, the new SICCO catalogue offers many interesting new products.

Best regards,

A handwritten signature in blue ink, appearing to read 'V. Bohlender', written in a cursive style.

Volker Bohlender

Managing Director



6 Fields of application
of Desiccators

8 Modifications/Made to measure

10 Guide to your ideal product

For dust- and humidity-free storage
or drying with Silicagel.



11 Desiccators for drying/storage

11 Desiccators for drying/storage
18 Mini-Desiccators
23 Desiccator Wall
28 Desiccators with UV protection
and Black

For storage of reactive substances.



37 Desiccators for gas-filling

For long-term storage.



43 Automatic-Desiccators

For storage of electronic components
in antistatic atmosphere.



49 Antistatic-Desiccators



For quick drying of substances and
O₂/CO₂-free storage.

»» 55 Vacuum-Desiccators

For safe handling of contaminated
substances.

»» 59 Glove Boxes/Extractor Hoods

60 Glove Boxes

64 Extractor Hoods

65 Accessories

73 Technical Information

74 Drying performance

78 Cleaning, Assembly of shelves

79 Efficient use of Silicagel

80 Optimise drying performance

81 Cable lead-ins

84 Materials

82 Company

You can rely on us.

Fields of application of Desiccators.

Appropriate solutions for any requirements

SICCO Desiccators and drying cabinets are used in different sectors. Available in different sizes as well as with a maximum of flexibility and functionality, they are covering the full spectrum of protected drying and storage.

Discover the large choice by means of some real life examples...



Electrical industry: **Protected temporary storage of electronic components.**

For example SICCO Desiccators Antistatic that protect sensitive electronic components such as boards against humidity and particles from the ambient air and in antistatic atmosphere.



Photographic industry: **Reliable equipment storage.**

For example the SICCO Maxi 2-Desiccator that is ideal for long-time storage of sensitive photo equipment and optical components in best possible conditions.

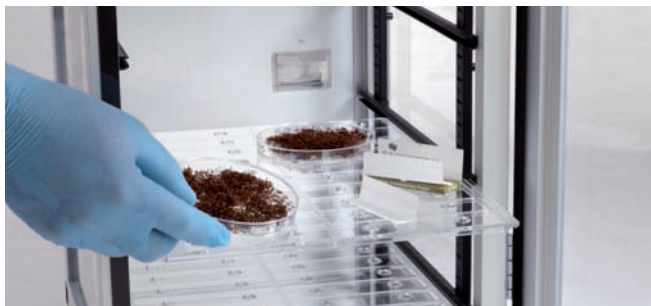

Tobacco industry: **Product-friendly long-term storage of tobacco and paper.**

For example the SICCO Auto-Star-Desiccator for automatic drying at constant humidity between 20 and 30%.



Metallography: **Stable storage of minerals and stones.**

For example the SICCO Maxi 1-Desiccator as robust depository with a frame made of aluminium profiles and shelves made of stainless steel for a total overload up to 160 kilos.



Museums and galleries:
Safe keeping of valuable pictures and virtu.

For example the SICCO Super-Big-Star-Desiccator with conserving effect, including hygrometer and tubing with quick couplings for gas-filling with pre-dried air.



Medicine:
Protection of sensitive tissue samples.

For example the SICCO Maxi 1-Desiccator that is usable with up to 34 shelves and a temperature resistance of -20°C up to $+70^{\circ}\text{C}$.



Industry/Laboratory:
Safe storage of retained samples.

For example the SICCO Super-Star-Desiccator that is usable with up to 26 acrylic glass shelves, circular rubber seal and cylinder lock.



Industry:
Space-saving and dry storage of labels.

For example the SICCO Maxi 1-Desiccator that is usable with up to 34 shelves, tray and hygrometer.



Laboratory:
Non-hazardous storage of bottles with toxic substances.

For example with the SICCO Maxi 2-Desiccator that has two separate compartments with door, tray and hygrometer.

Standard plus: our modifications...

The SICCO range already offers many options and a wide range of accessories for different applications. Moreover, we offer you to adapt our standard products according to your requirements. Sometimes it is only a small detail that has to be modified or added such as an additional connection to your exhaust air system.

Your benefit is an individual product as well as fast availability due to short-term realization of the modification. And what is your special request? We will be pleased to assist you: Just give us a call +49 (0) 9346-9286-0 or send us the enclosed "Made to measure"-sheet by fax.

Standard



Modification



A big flap instead of the split door for the supreme chamber.



Open for new possibilities – for example a glove box with connection for exhaust air system.



For perfect teamwork: Another pair of gloves for a second workstation in the glove box.



Open-minded for your plans: A closing device with gas-pressure spring instead of a traditional hinge-joint.

Or 100 Percent Individuality: Made to measure

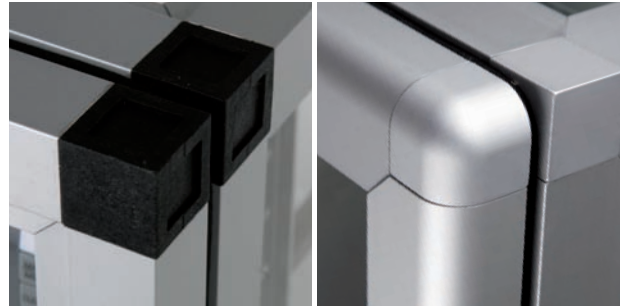

The SICCO standard product range already covers many extras and special requests. You are looking, however, for a special solution. Something that even BOHLENDER does not have in stock?

In this case we as a manufacturer offer “made to measure”-service. Just talk to our experts about your ideas, we will be glad to assist you – beginning with the construction and realizing manufacture exactly as per your request, starting with 1 piece. We only need a drawing (an approximate draft is enough) and some information.

Just give us a call +49 (0) 9346-9286-0 or send us the enclosed “Made to measure”-sheet by fax. We will contact you to discuss details. Afterwards, you will receive our non-binding and cost-free quotation.

Check-list for your Desiccator “made to measure”:

- » What is the application the desiccator is used for?
- » Which outside dimensions should your desiccator have?
- » What should be stored?
- » What material do you need for the desiccator panels?
- » How many shelves do you need?
- » What is the maximum expected weight? Per shelf, per desiccator?
- » Which accessories do you need (lock, connectors for gas-filling ...)?
- » How many desiccators do you need?
- » What is the maximum budget you would like to spend per desiccator?

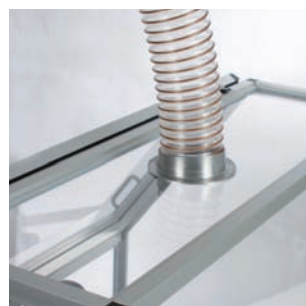
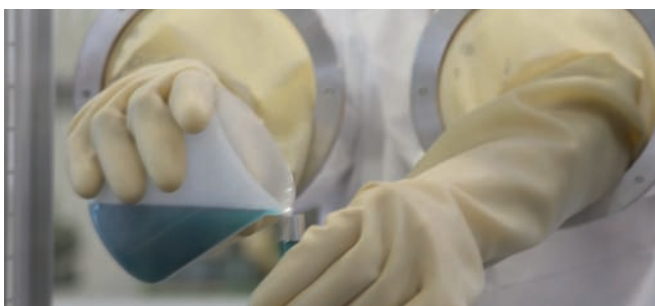
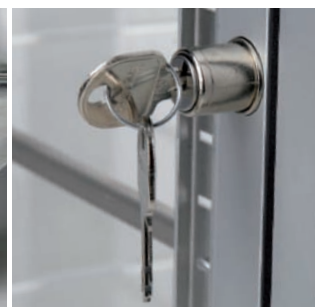

Guide to your ideal product.

You are not sure what is the best desiccator for your purpose? No problem: In this chart you will find the ideal product concerning application and requested size.

YOUR REQUIREMENTS	YOUR REQUIRED SPACE			
	Mini max. 212x162x180 mm (W x H x D) per compartment	Star max. 260x480x330 mm (W x H x D) per compartment	Big max. 495x500x540 mm (W x H x D) per compartment	Maxi max. 495x1.030x540 mm (W x H x D) per compartment
Humidity- and dust-free storage or drying of objects and/or substances	Mini-Desiccators Basic, Page 18 Mini-Desiccators Premium, Page 19	Star-Desiccator, Page 12 Star-Desiccator Horizontal, Page 13 Tower-Star-Desiccator, Page 13	Big-Star-Desiccator, Page 14 Desiccator-Wall, Page 24	Maxi 1-Desiccator, Page 14 Maxi 2-Desiccator, Page 15
Additionally temperature adjustable through heating with air circulation		Star-Thermo-Desiccator, Page 17		
Additional safety through integrated lock	Mini-Desiccators Secure Box, Page 20			
Mobile version with handy grip	Mini-Desiccators Mobile, Page 21			
Insertion of hot materials (up to 300°C) or especially aggressive media		Star-Vitrum-Desiccator, Page 25	Big-Star-Vitrum-Desiccator, Page 26	Maxi 1-Vitrum-Desiccator, Page 26 Maxi 2-Vitrum-Desiccator, Page 27
Storage of light-sensitive substances	Mini-Desiccators Protect, Pages 30-31	Star-Desiccator Protect, Page 28	Big-Star-Desiccator Protect, Page 29	Maxi 1-Desiccator Protect, Page 29 Maxi 2-Desiccator Protect, Page 30
Storage of substances to the exclusion of light and UV radiation	Mini-Desiccators Black, Page 35	Star-Desiccator Black, Page 32	Big-Star-Desiccator Black, Page 33	Maxi 1-Desiccator Black, Page 33 Maxi 2-Desiccator Black, Page 34
Storage of reactive substances respectively toxic chemicals with gas filling equipment	Mini-Desiccators Inertgas, Page 42	Super-Star-Desiccator, Page 38	Super-Big-Star-Desiccator, Page 39	Super-Maxi 1-Desiccator, Page 40 Super-Maxi 2-Desiccator, Page 41
Long-term storage with automatic drying at constant humidity between 20 and 30%		Auto-Star-Desiccator, Page 45	Auto-Big-Star-Desiccator, Page 46 Auto-Desiccator-Wall, Page 48	Auto-Maxi 1-Desiccator, Page 46 Auto-Maxi 2-Desiccator, Page 47
Storage of electronic components in antistatic atmosphere	Mini-Desiccators Antistatic, Page 52	Star-Desiccator Antistatic, Page 50	Big-Star-Desiccator Antistatic, Page 50 Desiccator-Wall Antistatic, Page 53	Maxi 1-Desiccator Antistatic, Page 51 Maxi 2-Desiccator Antistatic, Page 51
Storage of sensitive products in vacuum for especially quick drying		Vacuum-Desiccators, Pages 56-57		
Safe working with sensitive mixtures in isolated atmosphere	Glove Boxes and Extractor Hoods, from page 60			

Your requirement is not part of the list? Through the modification of our standard range and our “made to measure”-service, we will find the best solution for any enquiry. Let us know your wishes: either through the enclosed enquiry form or with a call on +49 (0) 9346 9286-0. We are looking forward to talking to you!

SICCO Desiccators for drying/storage

SICCO Desiccators are designed for storing or drying humidity sensitive products using silica gel. The tight fitting door protects the contents from contamination of the atmosphere. The controlled environment

inside the desiccators is ideal for storing reference materials, retained samples, metallographic specimens, tobacco and DNA samples.

Feature Summary

- » Reinforced aluminium frame with acrylic panels
- » Door with magnetic catch and circular rubber seal
- » Non-slip rubber feet or four casters (two of the casters with brakes)
- » Easy to read electronic hygrometer
- » Variable height shelves made of acrylic glass, stainless steel or aluminium
- » Telescopic shelves
- » Desiccant tray
- » Star-Desiccators include silica gel



SICCO BENEFITS

- » Reinforced aluminium frame with acrylic panels
- » Door with magnetic catch and circular rubber seal
- » Easy to read electronic hygrometer
- » Variable height shelves made of acrylic glass
- » Telescopic shelves
- » Non-slip rubber feet



BESTSELLER

SICCO Star-Desiccator

Panels:	Material:	Temperature resistance:	Use:	Stand:
clear	PMMA	-20 °C to +70 °C	normal pressure	rubber feet

Specification:

Aluminium frame with panels made of acrylic glass, including four shelves made of acrylic glass, tray, hygrometer and desiccant, usable with up to 26 shelves, stackable.

Cat. No.:	V 1871-07
Overall dimensions* W x H x D mm	310 x 525 x 375
Usable interior space W x H x D mm	260 x 480 x 330
Capacity liters	51
Weight kg/approx.	7
Maximum all-over load per shelf kg	10
Total all-over load kg	30



Add. accessories

Page 66–71.

*Overall dimensions are indicated as follows: width including hinge, height starting from base, depth without handle

SICCO Tower-Star-Desiccator

Panels: clear	Material: PMMA	Temperature resistance: -20 °C to +70 °C	Use: normal pressure	Stand: rubber feet
------------------	-------------------	---	-------------------------	-----------------------

Specification:

Aluminium frame with panels made of acrylic glass, including four shelves made of acrylic glass, tray, hygrometer and desiccant, usable with up to 38 shelves, stackable.

Cat. No.:	V 1938-07
Overall dimensions* W x H x D mm	310 x 735 x 375
Usable interior space W x H x D mm	260 x 690 x 330
Capacity liters	73
Weight kg/approx.	8
Maximum all-over load per shelf kg	10
Total all-over load kg	40



SICCO Star-Desiccator Horizontal

Panels: clear	Material: PMMA	Temperature resistance: -20 °C to +70 °C	Use: normal pressure	Stand: rubber feet
------------------	-------------------	---	-------------------------	-----------------------

Specification:

Aluminium frame with panels made of acrylic glass, including two shelves made of acrylic glass, tray, hygrometer and desiccant, usable with up to 13 shelves, stackable, door opens forward.

Cat. No.:	V 1899-07
Overall dimensions* W x H x D mm	525 x 340 x 375
Usable interior space W x H x D mm	480 x 260 x 330
Capacity liters	51
Weight kg/approx.	7
Maximum all-over load per shelf kg	1,5
Total all-over load kg	30

Applications:

Especially suitable for wide products such as A3 sheets or conductor boards.



SICCO Big-Star-Desiccator

Panels: clear	Material: PMMA	Temperature resistance: -20 °C to +70 °C	Use: normal pressure	Stand: rubber feet
-------------------------	--------------------------	--	--------------------------------	------------------------------

Specification:

Aluminium frame with panels made of acrylic glass, including two shelves made of stainless steel, tray and hygrometer, usable with up to 17 shelves.

Cat. No.:	V 1896-07
Overall dimensions* W x H x D mm	560 x 560 x 580
Usable interior space W x H x D mm	495 x 500 x 540
Capacity liters	156
Weight kg/approx.	18
Maximum all-over load per shelf kg	30
Total all-over load kg	80



SICCO Maxi 1-Desiccator

Panels: clear	Material: PMMA	Temperature resistance: -20 °C to +70 °C	Use: normal pressure	Stand: casters
-------------------------	--------------------------	--	--------------------------------	--------------------------

Specification:

Aluminium frame with panels made of acrylic glass, including four shelves made of stainless steel, tray and hygrometer, four casters, usable with up to 34 shelves.

Cat. No.:	V 1852-01
Overall dimensions* W x H x D mm	560 x 1150 x 580
Usable interior space W x H x D mm	495 x 1030 x 540
Capacity liters	311
Weight kg/approx.	30
Maximum all-over load per shelf kg	30
Total all-over load kg	160



BESTSELLER



BESTSELLER

SICCO Maxi 2-Desiccator

Panels:	Material:	Temperature resistance:	Use:	Stand:
clear	PMMA	-20 °C to +70 °C	normal pressure	casters

Specification:

Aluminium frame with panels made of acrylic glass, two compartments and two doors, including four shelves made of stainless steel, two trays and two hygrometers, four casters, usable with up to 17 shelves per compartment.

Cat. No.:	V 1853-01
Overall dimensions* W x H x D mm	560 x 1150 x 580
Usable interior space W x H x D mm	495 x 500 x 540 per compartment
Capacity liters	156 per compartment
Weight kg/approx.	34
Maximum all-over load per shelf kg	30
Total all-over load kg	80 per compartment



SICCO
Practical Tip
German Merk » Assembly

You do not have much space on your worktop and would like to stack your desiccators safely?

Just use our Connectors for Desiccators.

page 78



Drying properties

Please read our information on pages 74-75.



NEW

Thermo-Desiccator
for drying / storage

- » temperature adjustable
- » transparent
- » functional



The SICCO Heating with Air Circulation – how it works:

The fan on the back side sucks in the air inside the desiccator and blows it over the heating spiral. At the same time, the warmed air flows back into the desiccator. This air circulation provides an even heating of the interior space.

The temperature sensor inside monitors continuously the actual temperature. Once the temperature has reached the set value, the heating is switched off. The fan keeps on working for providing best heat distribution.

As soon as the internal temperature drops 2 °C below the set value, the heating is switched on again automatically.

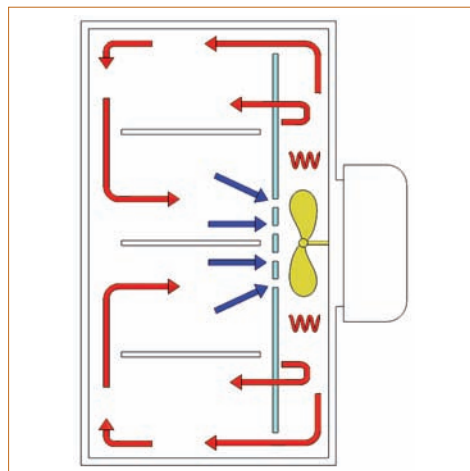

SICCO Star-Thermo-Desiccator

Panels: clear	Material: PMMA	Temperature resistance: -20 °C to +70 °C	Use: normal pressure	Stand: rubber feet
------------------	-------------------	---	-------------------------	-----------------------

Specification:

Aluminium frame with 2-pane-insulation (inside glass, outside acrylic glass), including four shelves made of acrylic glass, usable with up to 26 shelves. Integrated heating (850 W) with temperature sensor and air circulation. Electrical power connection 230 V / 50 Hz is required.

NEW

Cat.-No.:	V 1830-07
Overall dimensions* W x H x D mm	310 x 630 x 420
Usable interior space W x H x D mm	260 x 480 x 330
Addi. place requirement for heating mm	80 back side
Capacity liters	55
Weight kg, approx.	16
Maximum all-over load per shelf kg	2,5
Maximum all-over load kg	10
Temperature Setting	Room temperature plus 5 °C up to max. + 60 °C
Setting accuracy	1 °C
Deviation of temperature	approx. +/- 1,75 °C at 40 °C
Heating system	air circulation
Power consumption	850 W
Power connection	230 V / 50 Hz

Applications:

Ideal for warming of samples and substances in order to reduce reduction times or for temporary storage at constant ambient temperature.



BESTSELLER

SICCO Mini-Desiccators Basic

Panels: clear	Material: Polycarbonate	Temperature resistance: -35 °C to +70 °C	Use: normal pressure
-------------------------	-----------------------------------	--	--------------------------------

NEW

Version Mini 1:
Polycarbonate, one compartment, including desiccant, stackable.

A	Cat. No.:	V 1850-01
	Overall dimensions W x H x D mm	221 x 183 x 214
	Usable interior space W x H x D mm	212 x 162 x 180
	Capacity liters	6,2
	Weight kg	0,9
	Total all-over load kg	3

Version Mini 2:
Polycarbonate, two permanently fixed compartments, including desiccant, stackable.

B	Cat. No.:	V 1850-02
	Overall dimensions W x H x D mm	221 x 362 x 214
	Usable interior space W x H x D mm	212 x 162 x 180 per compartment
	Capacity liters	6,2 per compartment
	Weight kg	1,8
	Total all-over load kg	3

Version Mini 3:
Polycarbonate, three permanently fixed compartments, including desiccant, stackable.

C	Cat. No.:	V 1850-03
	Overall dimensions W x H x D mm	221 x 540 x 214
	Usable interior space W x H x D mm	212 x 162 x 180 per compartment
	Capacity liters	6,2 per compartment
	Weight kg	2,7
	Total all-over load kg	3



Add. accessories

Page 66-71.

*Overall dimensions are indicated as follows: width including hinge, height starting from base, depth without handle

SICCO Mini-Desiccators Premium

Panels: **clear**
 Material: **Polycarbonate**
 Temperature resistance: **-35 °C to +70 °C**
 Use: **normal pressure**

NEW

Version Mini 1:

Polycarbonate, one compartment, including two shelves, hygrometer and desiccant, non-slip rubber feet, stackable.

A	Cat. No.:	V 1950-01
	Overall dimensions W x H x D mm	221 x 183 x 214
	Usable interior space W x H x D mm	212 x 162 x 180
	Capacity liters	6,2
	Weight kg	0,9
	Maximum all-over load per shelf kg	2
	Total all-over load kg	3

Version Mini 2:

Polycarbonate, two permanently fixed compartments, including four shelves, two hygrometers and desiccant, non-slip rubber feet, stackable.

B	Cat. No.:	V 1950-02
	Overall dimensions W x H x D mm	221 x 183 x 214
	Usable interior space W x H x D mm	212 x 162 x 180 per compartment
	Capacity liters	6,2 per compartment
	Weight kg	0,9
	Maximum all-over load per shelf kg	2
	Total all-over load kg	3

Version Mini 3:

Polycarbonate, three permanently fixed compartments, including six shelves, three hygrometers and desiccant, non-slip rubber feet, stackable.

C	Cat. No.:	V 1950-03
	Overall dimensions W x H x D mm	221 x 183 x 214
	Usable interior space W x H x D mm	212 x 162 x 180 per compartment
	Capacity liters	6,2 per compartment
	Weight kg	0,9
	Maximum all-over load per shelf kg	2
	Total all-over load kg	3



SICCO Mini-Desiccator Secure Box Basic

Panels: clear	Material: Polycarbonate	Temperature resistance: -35 °C to +70 °C	Use: normal pressure
-------------------------	-----------------------------------	--	--------------------------------

Specification:

Polycarbonate, lockable, including desiccant, stackable.

NEW

Cat. No.:	V 1847-06
Overall dimensions W x H x D mm	221 x 183 x 214
Usable interior space W x H x D mm	212 x 162 x 180
Capacity liters	6,2
Weight kg	0,9
Total all-over load kg	3

Applications:

Safe storage of consumables, very handy.



SICCO Mini-Desiccator Secure Box Premium

Panels: clear	Material: Polycarbonate	Temperature resistance: -35 °C to +70 °C	Use: normal pressure
-------------------------	-----------------------------------	--	--------------------------------

Specification:

Polycarbonate, lockable, including two shelves, hygrometer and desiccant, non-slip rubber feet, stackable.

NEW

Cat. No.:	V 1947-06
Overall dimensions W x H x D mm	221 x 183 x 214
Usable interior space W x H x D mm	212 x 162 x 180
Capacity liters	6,2
Weight kg	0,9
Maximum all-over load per shelf kg	2
Total all-over load kg	3

Applications:

Safe storage of consumables, very handy.



Add. accessories

Page 66-71.

*Overall dimensions are indicated as follows: width including hinge, height starting from base, depth without handle

SICCO Mini-Mobile-Desiccator Basic

Panels: **clear** Material: **Polycarbonate** Temperature resistance: **-35 °C to +70 °C** Use: **normal pressure**

Specification:

Polycarbonate, with practical handle, including desiccant.

NEW

Cat. No.:	V 1848-06
Overall dimensions W x H x D mm	221 x 183 x 214
Usable interior space W x H x D mm	212 x 162 x 180
Capacity liters	6,2
Weight kg	1,0
Total all-over load kg	3



SICCO Mini-Mobile-Desiccator Premium

Panels: **clear** Material: **Polycarbonate** Temperature resistance: **-35 °C to +70 °C** Use: **normal pressure**

Specification:

Polycarbonate, with practical handle, including two shelves, hygrometer and desiccant, non-slip rubber feet.

NEW

Cat. No.:	V 1948-06
Overall dimensions W x H x D mm	221 x 183 x 214
Usable interior space W x H x D mm	212 x 162 x 180
Capacity liters	6,2
Weight kg	1,0
Maximum all-over load per shelf kg	2
Total all-over load kg	3

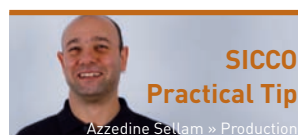
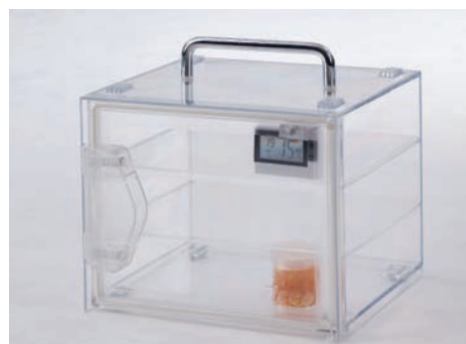

You are looking for a light-weight desiccator?

Our Mini-Desiccators have tight dimensions and can be easily transported due to their light weight.

Drying properties

Please read our information on pages 74-75.





Also made by BOHLENDER

Professional High-Performance Fluoroplastic Labware

Stirrer shafts, Magnetic stirring bars, Distributors for bottles or Tubes – these are just a few innovative BOLA products made of professional high-performance labware such as PTFE, PFA and FEP.

For fast and safe working in your laboratory.



Ask for our catalogue
free of charge.

- » More than 250 pages with professional high-performance labware and tips of our experts
- » Great selection and helpful service from BOHLENDER - as always

Info-Hotline:

+49 (0) 93 46-92 86 0

www.bola.de



Desiccator Wall
for drying and
storage

- » spacious
- » mobile
- » functional



SICCO Desiccator Wall

Panels: clear	Material: PMMA	Temperature resistance: -20 °C to +70 °C	Use: normal pressure	Stand: casters
-------------------------	--------------------------	--	--------------------------------	--------------------------

Specification:

Aluminium frame with panels made of acrylic glass, six compartments and six doors, including six shelves made of stainless steel, six trays and six hygrometers, four casters, usable with up to 17 shelves per compartment.

Cat. No.:	V 1994-08
Overall dimensions* W x H x D mm	1080 x 1870 x 580
Usable interior space W x H x D mm	495 x 500 x 540 per compartment
Capacity liters	156 per compartment
Weight kg, approx.	100
Maximum all-over load per shelf kg	30
Maximum all-over load kg	80 per compartment
Total all-over load kg	200
Ground clearance of lowest chamber mm	240





SICCO
Practical Tip

Uwe Hossfeld » Technical department

What is done if humidity does not decrease?

Check if the door closes tightly or if the sealing is damaged. Regenerate your desiccant or increase its portion. Check if the hygrometer is working correctly.

page 79



Vitrum BENEFITS

- » reinforced aluminium frame with borosilicate glass panels
- » for storing hot materials (up to max. 300 °C)
- » very good chemical resistance against aggressive products
- » variable height shelves made of stainless steel
- » easy to read electronic hygrometer
- » telescopic shelves



SICCO Star-Vitrum-Desiccator

Panels:	Material:	Temperature resistance:	Use:	Stand:
clear	borosilicate 3.3	-20 °C to +150 °C	normal pressure	rubber feet

Specification:

Aluminium frame with panels made of borosilicate glass 3.3, including four shelves made of stainless steel, tray, hygrometer and desiccant, usable with up to 26 shelves, stackable.

Cat. No.:	V 1841-07
Overall dimensions* W x H x D mm	310 x 525 x 375
Usable interior space W x H x D mm	260 x 480 x 330
Capacity liters	51
Weight kg/approx.	14
Maximum all-over load per shelf kg	10
Total all-over load kg	30

Applications:

Especially suitable for storing hot materials (max. 300°C), very good resistance compared to most acids and organic substances.



BESTSELLER

Drying properties

Please read our information on pages 74-75.



SICCO Big-Star-Vitrum Desiccator

Panels:	Material:	Temperature resistance:	Use:	Stand:
clear	borosilicate 3.3	-20 °C to +150 °C	normal pressure	rubber feet

Specification:

Aluminium frame with panels made of borosilicate glass 3.3, including two shelves made of stainless steel, tray and hygrometer, usable with up to 17 shelves.

NEW

Cat. No.:	V 1844-07
Overall dimensions* W x H x D mm	560 x 560 x 580
Usable interior space W x H x D mm	495 x 500 x 540
Capacity liters	156
Weight kg/approx.	22
Maximum all-over load per shelf kg	30
Total all-over load kg	80



SICCO Practical Tip
German Merk » Assembly

You do not have much space on your worktop and would like to stack your desiccators safely?

Just use our Connectors for Desiccators.

page 78

SICCO Maxi 1-Vitrum-Desiccator

Panels:	Material:	Temperature resistance:	Use:	Stand:
clear	borosilicate 3.3	-20 °C to +150 °C	normal pressure	casters

Specification:

Aluminium frame with panels made of borosilicate glass 3.3, including four shelves made of stainless steel, tray and hygrometer, four casters, usable with up to 34 shelves.

NEW

Cat. No.:	V 1846-07
Overall dimensions* W x H x D mm	560 x 1150 x 580
Usable interior space W x H x D mm	495 x 1030 x 540
Capacity liters	311
Weight kg/approx.	37
Maximum all-over load per shelf kg	30
Total all-over load kg	160



*** Add. accessories**
Page 66-71.

*Overall dimensions are indicated as follows: width including hinge, height starting from base, depth without handle

SICCO Maxi 2-Vitrum-Desiccator

Panels:	Material:	Temperature resistance:	Use:	Stand:
clear	borosilicate 3.3	-20 °C to +150 °C	normal pressure	casters

Specification:

Aluminium frame with panels made of borosilicate glass 3.3, two compartments and two doors, including four shelves made of stainless steel, two trays and two hygrometers, four casters, usable with up to 17 shelves per compartment.

Cat. No.:	V 1845-07
Overall dimensions* W x H x D mm	560 x 1150 x 580
Usable interior space W x H x D mm	495 x 500 x 540 per compartment
Capacity liters	156 per compartment
Weight kg/approx.	42
Maximum all-over load per shelf kg	30
Total all-over load kg	80 per compartment

Applications:

Especially suitable for storing hot materials (max. 300°C), very good resistance compared to most acids and organic substances.



Stable Desiccators

- »» Because of the aluminium frame and fiber-glass reinforced corner connections, the SICCO Desiccators are specially stable but also lightweight – ideal for our application. ««

Staff Member Forensic Unit

Drying properties

Please read our information on pages 74-75.





SICCO BENEFITS

- » orange panels reduce light incidence
- » protection against ultraviolet radiation
- » for storing of light-sensitive products
- » easy to read electronic hygrometer
- » variable height shelves

SICCO Star-Desiccator Protect

Panels: orange	Material: PMMA	Temperature resistance: -20 °C to +70 °C	Use: normal pressure	Stand: rubber feet
--------------------------	--------------------------	--	--------------------------------	------------------------------

Specification:

Aluminium frame, orange panels made of acrylic glass reduce light incidence and protect against ultraviolet radiation, including four shelves made of acrylic glass, tray, hygrometer and desiccant, usable with up to 26 shelves, stackable.

Cat. No.:	V 1879-07
Overall dimensions* W x H x D mm	310 x 525 x 375
Usable interior space W x H x D mm	260 x 480 x 330
Capacity liters	51
Weight kg/approx.	7
Maximum all-over load per shelf kg	10
Total all-over load kg	30

Applications:

Especially suitable for the storage of light-sensitive substances.



« Special Request »
+49 (0) 93 46-92 86-0



Add. accessories

Page 66-71.

*Overall dimensions are indicated as follows: width including hinge, height starting from base, depth without handle

SICCO Big-Star-Desiccator Protect

Panels:	Material:	Temperature resistance:	Use:	Stand:
orange	PMMA	-20 °C to +70 °C	normal pressure	rubber feet

Specification:

Aluminium frame, orange panels made of acrylic glass reduce light incidence and protect against ultraviolet radiation, including two shelves made of stainless steel, tray and hygrometer, usable with up to 17 shelves.

NEW

Cat. No.:	V 1926-07
Overall dimensions* W x H x D mm	560 x 560 x 580
Usable interior space W x H x D mm	495 x 500 x 540
Capacity liters	156
Weight kg/approx.	18
Maximum all-over load per shelf kg	30
Total all-over load kg	80



SICCO INNOVATION

Suspension arrangements and Rails

The rail system of the Star Desiccators is equipped with a consecutive numeration for an easy and fast positioning of the shelves.

page 78

SICCO Maxi 1-Desiccator Protect

Panels:	Material:	Temperature resistance:	Use:	Stand:
orange	PMMA	-20 °C to +70 °C	normal pressure	casters

Specification:

Aluminium frame, orange panels made of acrylic glass reduce light incidence and protect against ultraviolet radiation, including four shelves made of stainless steel, tray and hygrometer, four casters, usable with up to 34 shelves.

NEW

Cat. No.:	V 1927-07
Overall dimensions* W x H x D mm	560 x 1150 x 580
Usable interior space W x H x D mm	495 x 1030 x 540
Capacity liters	311
Weight kg/approx.	30
Maximum all-over load per shelf kg	30
Total all-over load kg	160

Applications:

Especially suitable for the storage of light-sensitive substances.



Drying properties

Please read our information on pages 74-75.



SICCO Maxi 2-Desiccator Protect

Panels: orange	Material: PMMA	Temperature resistance: -20 °C to +70 °C	Use: normal pressure	Stand: casters
--------------------------	--------------------------	--	--------------------------------	--------------------------

Specification:

Aluminium frame, orange panels made of acrylic glass reduce light incidence and protect against ultraviolet radiation, two compartments and two doors, including four shelves made of stainless steel, two trays and two hygrometers, four casters, usable with up to 17 shelves per compartment.

NEW

Cat. No.:	V 1928-07
Overall dimensions* W x H x D mm	560 x 1150 x 580
Usable interior space W x H x D mm	495 x 500 x 540 per compartment
Capacity liters	156 per compartment
Weight kg/approx.	34
Maximum all-over load per shelf kg	30
Total all-over load kg	80 per compartment



BESTSELLER

SICCO Mini-Desiccator Protect Basic

Panels: orange	Material: PMMA	Temperature resistance: -20 °C to +70 °C	Use: normal pressure
--------------------------	--------------------------	--	--------------------------------

Specification:

Orange polycarbonate reduces light incidence and protects against ultraviolet radiation, including desiccant, stackable.

Cat. No.:	V 1842-06
Overall dimensions W x H x D mm	221 x 183 x 214
Usable interior space W x H x D mm	212 x 162 x 180
Capacity liters	6,2
Weight kg	0,9
Total all-over load kg	3



Add. accessories

Page 66-71.

*Overall dimensions are indicated as follows: width including hinge, height starting from base, depth without handle

SICCO Mini-Desiccator Protect Premium

Panels: **orange** Material: **PMMA** Temperature resistance: **-20 °C to +70 °C** Use: **normal pressure**

Specification:

Orange polycarbonate reduces light incidence and protects against ultra-violet radiation, including two shelves, hygrometer and desiccant, non-slip rubber feet, stackable.

Cat. No.:	V 1942-06
Overall dimensions W x H x D mm	221 x 183 x 214
Usable interior space W x H x D mm	212 x 162 x 180
Capacity liters	6,2
Weight kg	0,9
Maximum all-over load per shelf kg	2
Total all-over load kg	3



SICCO INNOVATION

Mini-Desiccators

Because of the injection molding production, different materials can be used. So the Mini-Desiccators are specially versatile.



Drying properties

Please read our information on pages 74-75.

SICCO BENEFITS

- » reinforced aluminium frame
- » black, absolutely lightproof panels
- » for storing of light-sensitive products
- » variable height shelves
- » easy to read electronic hygrometer
- » telescopic shelves



SICCO Star-Desiccator Black

Panels: orange	Material: PMMA	Temperature resistance: -20 °C to +70 °C	Use: normal pressure	Stand: rubber feet
-------------------	-------------------	---	-------------------------	-----------------------

Specification:

Aluminium frame, panels made of black acrylic glass prevent light incidence and protect against ultraviolet radiation, including four shelves made of acrylic glass, tray, hygrometer and desiccant, usable with up to 26 shelves, stackable.

NEW

Cat. No.:	V 1891-07
Overall dimensions* W x H x D mm	310 x 525 x 375
Usable interior space W x H x D mm	260 x 480 x 330
Capacity liters	51
Weight kg/approx.	7
Maximum all-over load per shelf kg	10
Total all-over load kg	30

Applications:

Especially for the storage of substances to the exclusion of light transmission and ultraviolet radiation.

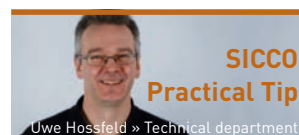

What is done if humidity does not decrease?

Check if the door closes tightly or if the sealing is damaged. Regenerate your desiccant or increase its portion. Check if the hygrometer is working correctly.



Add. accessories

Page 66-71.

SICCO Big-Star-Desiccator Black

Panels:	Material:	Temperature resistance:	Use:	Stand:
orange	PMMA	-20 °C to +70 °C	normal pressure	rubber feet

Specification:

Aluminium frame, panels made of black acrylic glass prevent light incidence and protect against ultraviolet radiation, including two shelves made of stainless steel, tray and hygrometer, usable with up to 17 shelves.

NEW

Cat. No.:	V 1939-07
Overall dimensions* W x H x D mm	560 x 560 x 580
Usable interior space W x H x D mm	495 x 500 x 540
Capacity liters	156
Weight kg/approx.	18
Maximum all-over load per shelf kg	30
Total all-over load kg	80



SICCO Maxi 1-Desiccator Black

Panels:	Material:	Temperature resistance:	Use:	Stand:
orange	PMMA	-20 °C to +70 °C	normal pressure	casters

Specification:

Aluminium frame, panels made of black acrylic glass prevent light incidence and protect against ultraviolet radiation, including four shelves made of stainless steel, tray and hygrometer, four casters, usable with up to 34 shelves.

NEW

Cat. No.:	V 1936-07
Overall dimensions* W x H x D mm	560 x 1150 x 580
Usable interior space W x H x D mm	495 x 1030 x 540
Capacity liters	311
Weight kg/approx.	30
Maximum all-over load per shelf kg	30
Total all-over load kg	160



Drying properties

Please read our information on pages 74-75.



SICCO Maxi 2-Desiccator Black

Panels: orange	Material: PMMA	Temperature resistance: -20 °C to +70 °C	Use: normal pressure	Stand: casters
--------------------------	--------------------------	--	--------------------------------	--------------------------

Specification:

Aluminium frame, panels made of black acrylic glass prevent light incidence and protect against ultraviolet radiation, two compartments and two doors, including four shelves made of stainless steel, two trays and two hygrometers, four casters, usable with up to 17 shelves per compartment.

NEW

Cat. No.:	V 1937-07
Overall dimensions* W x H x D mm	560 x 1150 x 580
Usable interior space W x H x D mm	495 x 500 x 540 per compartment
Capacity liters	156 per compartment
Weight kg/approx.	34
Maximum all-over load per shelf kg	30
Total all-over load kg	80 per compartment

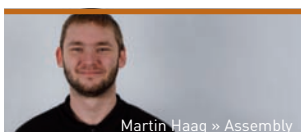

Martin Haag » Assembly

How can you regenerate Silica Gel?

Just put the tray with the desiccant for 90 minutes at 90-100° C in the oven. Attention: A microwave is unsuitable for this process.

page 79



Add. accessories

Page 66-71.

*Overall dimensions are indicated as follows: width including hinge, height starting from base, depth without handle

SICCO Mini-Desiccator Black Basic

Panels: **orange** Material: **PMMA** Temperature resistance: **-20 °C to +70 °C** Use: **normal pressure**

Specification:

Black polycarbonate prevents light incidence and protects against ultraviolet radiation, including desiccant, stackable.

NEW

Cat. No.:	V 1840-06
Overall dimensions W x H x D mm	221 x 183 x 214
Usable interior space W x H x D mm	212 x 162 x 180
Capacity liters	6,2
Weight kg	0,9
Total all-over load kg	3



SICCO Mini-Desiccator Black Premium

Panels: **orange** Material: **PMMA** Temperature resistance: **-20 °C to +70 °C** Use: **normal pressure**

Specification:

Black polycarbonate prevents light incidence and protects against ultraviolet radiation, including two shelves, hygrometer and desiccant, non-slip rubber feet, stackable.

NEW

Cat. No.:	V 1940-06
Overall dimensions W x H x D mm	221 x 183 x 214
Usable interior space W x H x D mm	212 x 162 x 180
Capacity liters	6,2
Weight kg	0,9
Maximum all-over load per shelf kg	2
Total all-over load kg	3



Drying properties

Please read our information on pages 74-75.





SICCO Desiccators for gas filling

Gas filling SICCO Desiccators provide ideal conditions for the safe and secure storing of poisonous chemicals. Rare or inert gases like nitrogen can be introduced as

soon as the door is closed tightly. Compared to the ambient air the inert gas does not react with the stored substances.

Feature Summary

- » Reinforced aluminium frame with acrylic panels
- » Door with magnetic catch, circular rubber seal, the Super-Star-Desiccator includes a cylinder lock
- » Non-slip rubber feet or four casters (two of the casters with brakes)
- » Extra large electronic hygrometer
- » Variable height shelves made of acrylic glass, stainless steel or aluminium
- » Telescopic shelves
- » Two connections for gas filling including quick couplings with self-sealing valves and hose

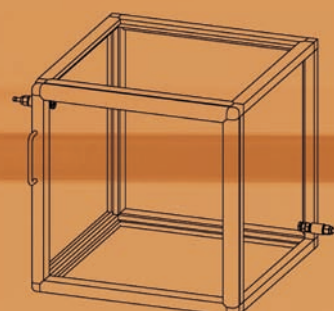

SICCO BENEFITS

- » reinforced aluminium frame with acrylic panels
- » door with magnetic catch and circular seal
- » easy to read electronic hygrometer
- » variable height shelves
- » connections for gas-filling including quick couplings with self-sealing valves and hose
- » telescopic shelves



SICCO Super-Star-Desiccator

Panels:	Material:	Temperature resistance:	Use:	Stand:
clear	PMMA	-20 °C to +70 °C	normal pressure	rubber feet

Specification:

Aluminium frame with panels made of acrylic glass, including four shelves made of acrylic glass, tray, hygrometer, desiccant and hose (5 m) with two quick couplings for gas filling, usable with up to 26 shelves, stackable.

Cat. No.:	V 1875-07
Overall dimensions* W x H x D mm	310 x 525 x 375
Addi. place requirement for coupling mm	150 per panel
Usable interior space W x H x D mm	260 x 480 x 330
Capacity liters	51
Weight kg/approx.	7
Maximum all-over load per shelf kg	10
Total all-over load kg	30
Bore diameter of quick coupling mm	Ø 6
Bore diameter in panels mm	Ø 16,5 – upper left front side lower right back side



BESTSELLER



Add. accessories

Page 66–71.

*Overall dimensions are indicated as follows: width including hinge, height starting from base, depth without handle

SICCO Super-Big-Star-Desiccator

Panels:	Material:	Temperature resistance:	Use:	Stand:
clear	PMMA	-20 °C to +70 °C	normal pressure	rubber feet

Specification:

Aluminium frame with panels made of acrylic glass, including two shelves made of stainless steel, tray, hygrometer and hose (5 m) with two quick couplings for gas filling, usable with up to 17 shelves.

NEW

Cat. No.:	V 1935-07
Overall dimensions* W x H x D mm	560 x 560 x 580
Addi. place requirement for coupling mm	150 per panel
Usable interior space W x H x D mm	495 x 500 x 540
Capacity liters	156
Weight kg/approx.	18
Maximum all-over load per shelf kg	30
Total all-over load kg	80
Bore diameter of quick coupling mm	Ø 6
Bore diameter in panels mm	Ø 16,5 – <small>upper left front side lower right back side</small>

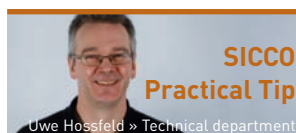
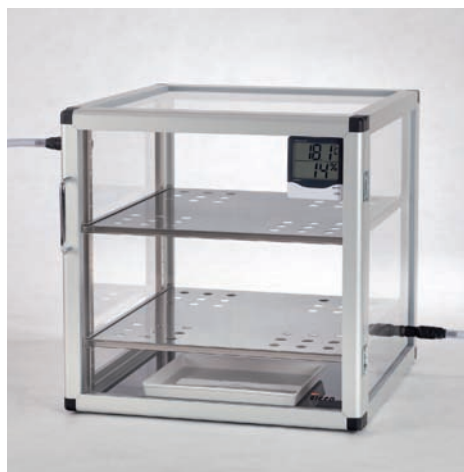

Uwe Hossfeld » Technical department

Fast drying without nitrogen

By the supply of pre-dried air from your compressed air system into the SICCO Desiccator for gas filling, you can dry your products fast and favorably.

Drying properties

Please read our information on pages 74-75.



SICCO Super-Maxi 1-Desiccator

Panels: clear	Material: PMMA	Temperature resistance: -20 °C to +70 °C	Use: normal pressure	Stand: casters
-------------------------	--------------------------	--	--------------------------------	--------------------------

Specification:

Aluminium frame with panels made of acrylic glass, including four shelves made of stainless steel, tray, hygrometer and hose (5 m) with two quick couplings for gas filling, four casters, usable with up to 34 shelves.

Cat. No.:	V 1932-01
Overall dimensions* W x H x D mm	560 x 1150 x 580
Addi. place requirement for coupling mm	150 per panel
Usable interior space W x H x D mm	495 x 1030 x 540
Capacity liters	311
Weight kg/approx.	30
Maximum all-over load per shelf kg	30
Total all-over load kg	160
Bore diameter of quick coupling mm	Ø 6
Bore diameter in panels mm	Ø 16,5 – <small>upper left front side lower right back side</small>



SICCO INNOVATION

Optimal circulation

The shelves have holes. Thereby the whole inside air is circulating and the drying procedure will be accelerated; even with maximum load.



Add. accessories

Page 66–71.

*Overall dimensions are indicated as follows: width including hinge, height starting from base, depth without handle

SICCO Super-Maxi 2-Desiccator

Panels: clear	Material: PMMA	Temperature resistance: -20 °C to +70 °C	Use: normal pressure	Stand: casters
------------------	-------------------	---	-------------------------	-------------------

Specification:

Aluminium frame with panels made of acrylic glass, two compartments and two doors, including four shelves made of stainless steel, two trays, two hygrometers and hose (2x 5 m) with four quick couplings for gas filling, four casters, usable with up to 17 shelves per compartment.

Cat. No.:	V 1933-01
Overall dimensions* W x H x D mm	560 x 1150 x 580
Addi. place requirement for coupling mm	150 per panel
Usable interior space W x H x D mm	495 x 500 x 540 per compartment
Capacity liters	156 pro Kammer
Weight kg/approx.	34
Maximum all-over load per shelf kg	30
Total all-over load kg	80 per compartment
Bore diameter of quick coupling mm	Ø 6 per compartment
Bore diameter in panels mm	Ø 16,5 – upper left front side lower right back side

SICCO Praxis-Tipp
Christian Stöhr » Technical department

Where is the best position for Silica Gel?

Just place your components directly next to the Silicagel where humidity is absorbed most quickly.



SICCO Mini-Desiccator for Gas Filling Basic

Panels:	Material:	Temperature resistance:	Use:
clear	PMMA	-20 °C to +70 °C	normal pressure

Specification:

Polycarbonate, including desiccant and hose (5 m) with two quick couplings for gas filling, stackable.

NEW

Cat. No.:	V 1849-06
Overall dimensions W x H x D mm	221 x 183 x 214
Addi. place requirement for coupling mm	150
Usable interior space W x H x D mm	212 x 162 x 180
Capacity liters	6,2
Weight kg	0,9
Total all-over load kg	3

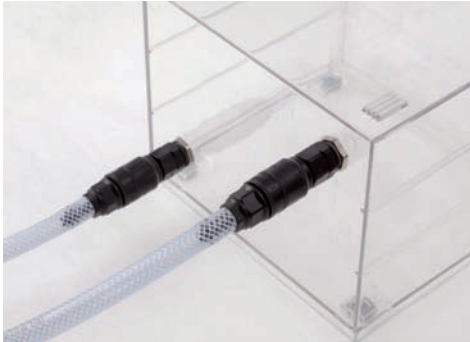

SICCO Mini-Desiccator for Gas Filling Premium

Panels:	Material:	Temperature resistance:	Use:
clear	PMMA	-20 °C to +70 °C	normal pressure

Specification:

Polycarbonate, including two shelves, hygrometer, desiccant and hose (5 m) with two quick couplings for gas filling, non-slip rubber feet, stackable.

NEW

Cat. No.:	V 1949-06
Overall dimensions W x H x D mm	221 x 183 x 214
Addi. place requirement for coupling mm	150
Usable interior space W x H x D mm	212 x 162 x 180
Capacity liters	6,2
Weight kg	0,9
Maximum all-over load per shelf kg	2
Total all-over load kg	3

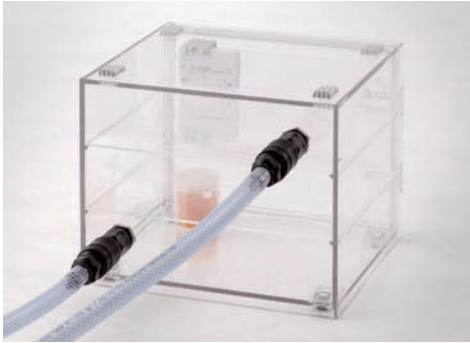

Add. accessories

Page 66-71.

*Overall dimensions are indicated as follows: width including hinge, height starting from base, depth without handle

SICCO Automatic-Desiccators

With automatic drying that can maintain a constant humidity of between 20% and 30%, SICCO Automatic Desiccators are suitable for long-term storage. Even frequent opening of the door is compensated automa-

tically. They are the ideal solution for storing reference samples, electronics, photo equipment, papers, valuable cultural assets and much more.

Feature Summary

- » Reinforced aluminium frame with acrylic panels
- » Door with magnetic catch and circular rubber seal
- » Non-slip rubber feet or four casters (two of the casters with brakes)
- » Easily readable electronic hygrometer
- » Variable height shelves made of acrylic glass, stainless steel or aluminium
- » Automatic drying (manual regeneration of desiccant is not necessary)
- » Constant low interior humidity between 20% and 30%
- » Telescopic shelves



SICCO Electronic Dehumidification System -

How it works:

The essential components of the drying unit are dustless, colour-changing silica gel desiccant beads and two fans.

The automatic dehumidification and desiccant regeneration cycle operates continuously every 20 minutes as follows:

The circulating fan draws for 14 minutes interior chamber air across the desiccant and thus dehumidifies the chamber. During this phase, the one-way flap valves are open to the interior of the desiccator and closed to the exterior.

Afterwards the circulating fan is stopped and the silica gel is heated electronically to initiate its regeneration. After one minute, the regeneration fan starts to operate and draws air in an opposite direction to the first fan. Due to the air flow, the one-way flap valves to the interior of the chamber are closed and the valves to the exterior environment are open. The desiccant is heated for another four minutes to release the captured moisture to the ambient air.

At the end of the cycle, the circulating fan operates for one minute with ambient air to cool down the desiccant to the ambient temperature. Then the cycle starts again.

Drying Cycle

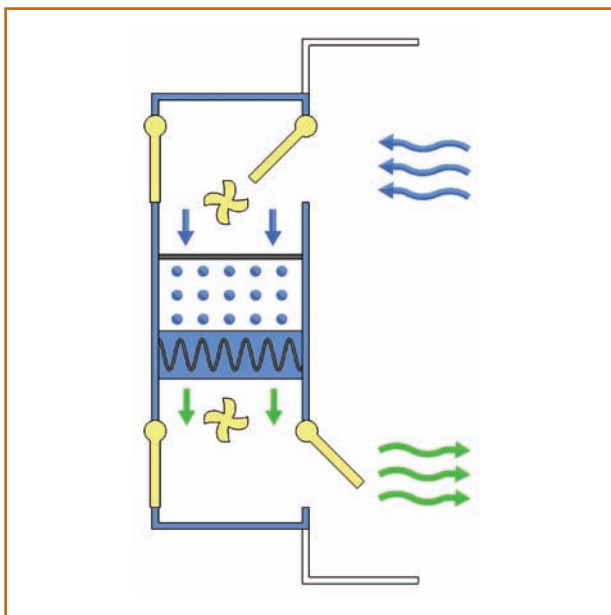

Regeneration Cycle

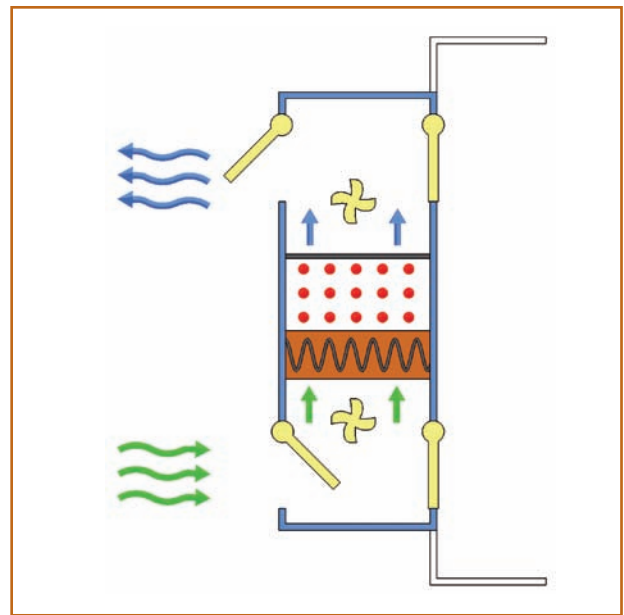

BESTSELLER

SICCO Auto-Star-Desiccator

Panels:	Material:	Temperature resistance:	Use:	Stand:
clear	PMMA	-20 °C to +70 °C	normal pressure	rubber feet

Specification:

Aluminium frame with panels made of acrylic glass, rear panel made of aluminium, including four shelves made of acrylic glass, hygrometer and mounted drying unit, usable with up to 26 shelves, stackable. Electrical power connection 230 V / 50 Hz is required.

Cat. No.:	V 1877-07
Overall dimensions* W x H x D mm	310 x 525 x 375
Excess length of drying unit mm	70 back side
Usable interior space W x H x D mm	260 x 480 x 330
Capacity liters	51
Weight kg/approx.	7,3
Maximum all-over load per shelf kg	10
Total all-over load kg	30

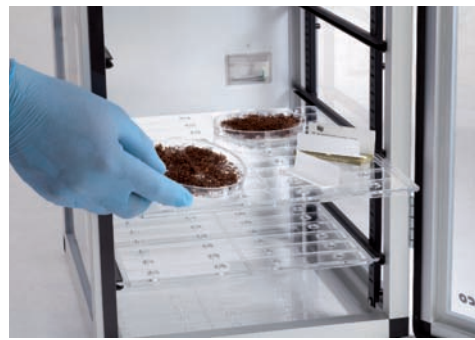

Shelves

» The shelves can be inserted in flexible heights. Even the products in the back of the desiccator are easily reachable due to the telescopic shelves. «

Technician, Analysis of retain samples



Drying properties

Please read our information on pages 76-77.

SICCO Auto-Big-Star-Desiccator

Panels: clear	Material: PMMA	Temperature resistance: -20 °C to +70 °C	Use: normal pressure	Stand: rubber feet
-------------------------	--------------------------	--	--------------------------------	------------------------------

Specification:

Aluminium frame with panels made of acrylic glass, including two shelves made of stainless steel, hygrometer and mounted drying unit, usable with up to 17 shelves. Electrical power connection 230 V / 50 Hz is required.

NEW

Cat. No.:	V 1894-07
Overall dimensions* W x H x D mm	560 x 560 x 580
Excess length of drying unit mm	100 back side
Usable interior space W x H x D mm	495 x 500 x 540
Capacity liters	156
Weight kg/approx.	22
Maximum all-over load per shelf kg	30
Total all-over load kg	80

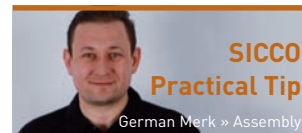

You do not have much space on your worktop and would like to stack your desiccators safely?

Just use our Connectors for Desiccators.

page 78

SICCO Auto-Maxi 1-Desiccator

Panels: clear	Material: PMMA	Temperature resistance: -20 °C to +70 °C	Use: normal pressure	Stand: casters
-------------------------	--------------------------	--	--------------------------------	--------------------------

Specification:

Aluminium frame with panels made of acrylic glass, including four shelves made of stainless steel, hygrometer and mounted drying unit, four casters, usable with up to 34 shelves. Electrical power connection 230 V / 50 Hz is required.

Cat. No.:	V 1914-01
Overall dimensions* W x H x D mm	560 x 1150 x 580
Excess length of drying unit mm	100 back side
Usable interior space W x H x D mm	495 x 1030 x 540
Capacity liters	311
Weight kg/approx.	31
Maximum all-over load per shelf kg	30
Total all-over load kg	160



Add. accessories

Page 66-71.

*Overall dimensions are indicated as follows: width including hinge, height starting from base, depth without handle

SICCO Auto-Maxi 2-Desiccator

Panels: clear	Material: PMMA	Temperature resistance: -20 °C to +70 °C	Use: normal pressure	Stand: casters
------------------	-------------------	---	-------------------------	-------------------

Specification:

Aluminium frame with panels made of acrylic glass, two compartments and two doors, including four shelves made of stainless steel, two hygrometers and mounted drying unit, four casters, usable with up to 17 shelves per compartment. Electrical power connection 230 V / 50 Hz is required.

Cat. No.:	V 1916-01
Overall dimensions* W x H x D mm	560 x 1150 x 580
Excess length of drying unit mm	100 back side
Usable interior space W x H x D mm	495 x 500 x 540 per compartment
Capacity liters	156 per compartment
Weight kg/approx.	35
Maximum all-over load per shelf kg	30
Total all-over load kg	80 per compartment





SICCO
Practical Tip

Christian Stöhr » Technical department

You need more space in your desiccator?

We offer the optimal solution: All desiccators can be equipped with further removable shelves.



Drying properties

Please read our information on pages 76-77.

SICCO Auto-Desiccator Wall

Panels: clear	Material: PMMA	Temperature resistance: -20 °C to +70 °C	Use: normal pressure	Stand: casters
-------------------------	--------------------------	--	--------------------------------	--------------------------

Specification:

Aluminium frame with panels made of acrylic glass, six compartments and six doors, including six shelves made of stainless steel, six hygrometers and mounted drying unit, four casters, usable with up to 17 shelves per compartment. Electrical power connection 230 V / 50 Hz is required.

Cat. No.:	V 1995-08
Overall dimensions* W x H x D mm	1080 x 1870 x 580
Excess length of drying unit mm	100 back side
Usable interior space W x H x D mm	495 x 500 x 540 per compartment
Capacity liters	156 per compartment
Weight kg, approx	100
Maximum all-over load per shelf kg	30
Maximum all-over load kg	80 per compartment
Total all-over load kg	200
Ground clearance of lowest chamber mm	240
Automatic drying units	2 per compartment





SICCO
Practical Tip

Andreas Bruder » Final quality control

How can you accelerate the drying procedure?

By increasing the circulation of air. Just put a small electricity or solar driven ventilator in the inside space.

page 80

*** Add. accessories**
Page 66-71.

*Overall dimensions are indicated as follows: width including hinge, height starting from base, depth without handle

SICCO Antistatic-Desiccators

SICCO Antistatic-Desiccators can protect electronic components against humidity and airborne particulate. Electrostatic charges are discharged by a grounding cable and a charge neutral atmosphere is produced

inside the desiccator. Antistatic-Desiccators are mainly used for temporary storage of components for electronic products.

Feature Summary

- » Reinforced aluminium frame with antistatic acrylic panels
- » Door with magnetic catch and circular rubber seal
- » Non-slip rubber feet or four casters (two of the casters with brakes)
- » Easily readable electronic hygrometer
- » Variable height shelves made of aluminium or stainless steel
- » Telescopic shelves
- » Connection for grounding cable
- » Tray for desiccant
- » Star-Desiccators include silica gel



SICCO Star-Desiccator Antistatic

Panels:	Material:	Temperature resistance:	Use:	Stand:
bluish	PC - ESD	-20 °C to +70 °C	normal pressure	rubber feet

Specification:

Aluminium frame with static dissipative panels made of polycarbonate, including four aluminium shelves, tray, hygrometer and desiccant, usable with up to 26 shelves, stackable. All materials used can discharge electrostatic charging by means of a grounding cable which can be connected on the back side (connecting thread M6).

Cat. No.:	V 1910-07
Overall dimensions* W x H x D mm	310 x 525 x 375
Usable interior space W x H x D mm	260 x 480 x 330
Capacity liters	51
Weight kg/approx.	7
Maximum all-over load per shelf kg	10
Total all-over load kg	30



SICCO Big-Star-Desiccator Antistatic

Panels:	Material:	Temperature resistance:	Use:	Stand:
bluish	PC - ESD	-20 °C to +70 °C	normal pressure	rubber feet

Specification:

Aluminium frame with static dissipative panels made of polycarbonate, including two shelves made of stainless steel, tray and hygrometer, usable with up to 17 shelves. All materials used can discharge electrostatic charging by means of a grounding cable which can be connected on the back side (connecting thread M6).

NEW

Cat. No.:	V 1925-07
Overall dimensions* W x H x D mm	560 x 560 x 580
Usable interior space W x H x D mm	495 x 500 x 540
Capacity liters	156
Weight kg/approx.	18
Maximum all-over load per shelf kg	30
Total all-over load kg	80



Add. accessories

Page 66-71.

*Overall dimensions are indicated as follows: width including hinge, height starting from base, depth without handle

SICCO Maxi 1-Desiccator Antistatic

Panels:	Material:	Temperature resistance:	Use:	Stand:
bluish	PC - ESD	-20 °C to +70 °C	normal pressure	casters

Specification:

Aluminium frame with static dissipative panels made of polycarbonate, including four shelves made of stainless steel, tray and hygrometer, four casters, usable with up to 34 shelves. All materials used can discharge electrostatic charging by means of a grounding cable which can be connected on the back side (connecting thread M6).

Cat. No.:	V 1922-07
Overall dimensions* W x H x D mm	560 x 1150 x 580
Usable interior space W x H x D mm	495 x 1030 x 540
Capacity liters	311
Weight kg/approx.	30
Maximum all-over load per shelf kg	30
Total all-over load kg	160



SICCO INNOVATION

Desiccators for wall-mounting

A space-saving alternative to the standard desiccator is the desiccator for wall-mounting. We as manufacturer offer your customized wall-mounted desiccator.

SICCO Maxi 2-Desiccator Antistatic

Panels:	Material:	Temperature resistance:	Use:	Stand:
bluish	PC - ESD	-20 °C to +70 °C	normal pressure	casters

Specification:

Aluminium frame with static dissipative panels made of polycarbonate, two compartments and two doors, including four shelves made of stainless steel, two trays and two hygrometers, four casters, usable with up to 17 shelves per compartment. All materials used can discharge electrostatic charging by means of a grounding cable which can be connected on the back side (connecting thread M6).

Cat. No.:	V 1923-07
Overall dimensions* W x H x D mm	560 x 1150 x 580
Usable interior space W x H x D mm	495 x 500 x 540 per compartment
Capacity liters	156 per compartment
Weight kg/approx.	34
Maximum all-over load per shelf kg	30
Total all-over load kg	80 per compartment



Drying properties

Please read our information on pages 74-75.

SICCO Mini-Desiccator Antistatic Basic

Panels: bluish	Material: PC - ESD	Temperature resistance: -20 °C to +70 °C	Use: normal pressure
--------------------------	------------------------------	--	--------------------------------

Specification:

Black, static dissipative polycarbonate, including desiccant, stackable. All materials used can discharge electrostatic charging by means of a grounding cable which can be connected on the back side (bore dia. 4,3 mm).

NEW

Cat.No.:	V 1843-06
Overall dimensions* W x H x D mm	221 x 182 x 214
Usable interior space W x H x D mm	212 x 162 x 180
Capacity liters	6,2
Weight kg.	0,9
Total all-over load kg	3
Surface resistivity Ohm	10 ⁵



SICCO Mini-Desiccator Antistatic Premium

Panels: bluish	Material: PC - ESD	Temperature resistance: -20 °C to +70 °C	Use: normal pressure
--------------------------	------------------------------	--	--------------------------------

Specification:

Black, static dissipative polycarbonate, including two shelves made of static dissipative polyethylene, hygrometer and desiccant, non-slip rubber feet, stackable. All materials used can discharge electrostatic charging by means of a grounding cable which can be connected on the back side (bore dia. 4,3 mm).

NEW

Cat.No.:	V 1943-06
Overall dimensions* W x H x D mm	221 x 182 x 214
Usable interior space W x H x D mm	212 x 162 x 180
Capacity liters	6,2
Weight kg.	0,9
Maximum all-over load per shelf kg	2
Total all-over load kg	3
Surface resistivity Ohm	10 ⁵



Add. accessories

Page 66-71.

*Overall dimensions are indicated as follows: width including hinge, height starting from base, depth without handle

SICCO Desiccator Wall Antistatic

Panels:	Material:	Temperature resistance:	Use:	Stand:
bluish	PC - ESD	-20 °C to +70 °C	normal pressure	casters

Specification:

Aluminium frame with static dissipative panels made of polycarbonate, six compartments and six doors, including six shelves made of stainless steel, six trays and six hygrometers, four casters, usable with up to 17 shelves per compartment. All materials used can discharge electrostatic charging by means of a grounding cable which can be connected on the back side (connecting thread M6).

Cat. No.:	V 1997-08
Overall dimensions* W x H x D mm	1080 x 1870 x 580
Usable interior space W x H x D mm	495 x 500 x 540 per compartment
Capacity liters	156 per compartment
Weight kg, approx	100
Maximum all-over load per shelf kg	30
Maximum all-over load kg	80 per compartment
Total all-over load kg	200
Ground clearance of lowest chamber mm	240





SICCO
Practical Tip

Marion Stoppel » Construction

How can you reduce the air exchange when opening the door?

Form an artificial wall by putting large jars in the front part of the desiccator or glue a paper or a film in the gaps.

page 80



Drying properties

Please read our information on pages 74-75.



SICCO Vacuum-Desiccators

SICCO Vacuum-Desiccators are suitable for storing sensitive products in a vacuum. The vacuum inside the desiccator ensures rapid drying of the stored products.

These systems allow storage in an oxygen and carbon dioxide free environment and are, for example, suitable for storage of semiconductor samples.

Feature Summary

- » Clear acrylic panels, interior is visible from all sides
- » Circular silicone seal
- » Non-slip rubber feet
- » Variable height shelves
- » Vacuum gauge (0-760 mm of mercury)
- » Vacuum up to 10^{-4} Torr
- » Two needle valves with O.D. 9.0 mm

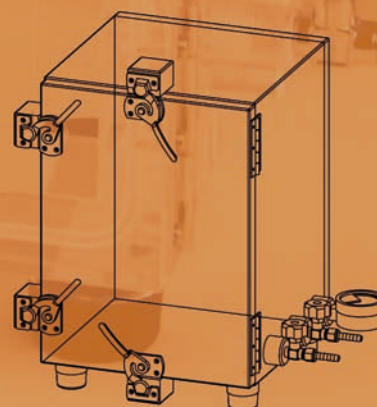



BESTSELLER

SICCO Vacuum 1-Desiccator

Panels:	Material:	Temperature resistance:	Use:	Stand:
clear	PMMA	-20 °C to +70 °C	Vacuum up to 10 ⁻⁴ Torr	rubber feet

Specification:

Massive acrylic glass (wall thickness 20 mm), door with circular silicone gasket and four latches, vacuum gauge, two needle valves with hose connectors, including two shelves, usable with up to three shelves.

Cat. No.:	V 1880-04
Overall dimensions* W x H x D mm	300 x 340 x 300
Excess length of valves + vacuum gauge mm	100
Usable interior space W x H x D mm	260 x 260 x 260
Capacity liters	18
Weight kg	15
Maximum all-over load kg	9
Total all-over load kg	30



Add. accessories

Page 66-71.

*Overall dimensions are indicated as follows: width including hinge, height starting from base, depth without handle

SICCO Vacuum 2-Desiccator

Panels: clear	Material: PMMA	Temperature resistance: -20 °C to +70 °C	Use: Vacuum up to 10 ⁻⁴ Torr	Stand: rubber feet
------------------	-------------------	---	--	-----------------------

Specification:

Massive acrylic glass (wall thickness 20 mm), door with circular silicone gasket and four latches, vacuum gauge, two needle valves with hose connectors, including three shelves, usable with up to 5 shelves.

Cat. No.:	V 1880-08
Overall dimensions* W x H x D mm	300 x 340 x 300
Excess length of valves + vacuum gauge mm	100
Usable interior space W x H x D mm	260 x 260 x 260
Capacity liters	25
Weight kg	18
Maximum all-over load kg	9
Total all-over load kg	40



SICCO Vacuum 3-Desiccator

Panels: clear	Material: PMMA	Temperature resistance: -20 °C to +70 °C	Use: Vacuum up to 10 ⁻⁴ Torr	Stand: rubber feet
------------------	-------------------	---	--	-----------------------

Specification:

Massive acrylic glass (wall thickness 20 mm), door with circular silicone gasket and 5 latches, vacuum gauge, two needle valves with hose connectors, including four shelves, usable with up to 7 shelves.

Cat. No.:	V 1880-12
Overall dimensions* W x H x D mm	315 x 550 x 310
Excess length of valves + vacuum gauge mm	100
Usable interior space W x H x D mm	265 x 460 x 260
Capacity liters	32
Weight kg	27
Maximum all-over load kg	9
Total all-over load kg	50





SICCO Glove Boxes/Extractor Hoods

The SICCO Glove Boxes allow safe working with sensitive compounds in a controlled environment. The natural rubber gloves provide you with the necessary mobility for a safe handling.

The connectors for gas filling allow to flush the workspace as well as the transfer chamber with inert gas.

By means of the transfer chamber, the glove boxes can be easily loaded.

Feature Summary

- » Robust and light-weight aluminium construction
- » Large front opening
- » Superb all-round visibility, non-glare
- » Non-slip rubber feet
- » Cable lead-ins for electric devices
- » Gas-filling connectors including quick couplings with self-sealing valves and hose
- » Transfer chamber for inserting further products

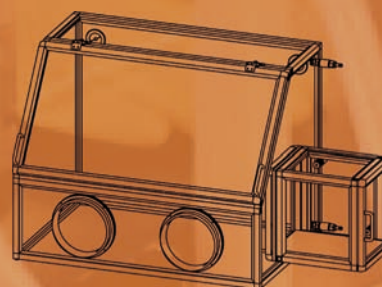



How to work with the SICCO Glove Box with Transfer Chamber

Glove Boxes are used whenever sensitive or hazardous materials have to be processed in an isolated environment.

With the big opening, all necessary equipment such as balances, syringes, or pipettes can be installed prior to start your work. Electrical power supply is assured by the integrated lead-ins for cables on the back side - any standard cables with an outer diameter from 0,1 up to 10 mm can be led in including mounted plugs.

Once the door is closed, the inner space can be flushed with nitrogen or inert gas by using the integrated connectors for gas-filling. Probes for e. g. monitoring the oxygen content can be installed, if necessary, by using the lead-ins on the back side.

Particular attention is paid to ergonomics: The position of the openings for the gloves allows to use the full capacity. The tilted door panel provides a glare-free and good sight on the interior.

Using the transfer chamber, additional products can be easily inserted into the glove box. Upon opening of the inner door, the tray extends into the interior for easy access to inserted products. The transfer chamber can be independently filled with gas.

You are looking for a glove box with different dimensions or need further options? Its modular construction with a frame made of aluminium profiles and acrylic glass panels allows to adapt our glove box to your special requirements.

SICCO Glove Box with Transfer Chamber

Panels: clear	Material: PMMA	Temperature resistance: -20 °C to +70 °C	Use: normal pressure	Stand: rubber feet
------------------	-------------------	---	-------------------------	-----------------------

Specification:

Aluminium frame with panels made of acrylic glass, base panel made of polyethylene, including hose (2x 5 m) with four quick couplings for gas filling of workspace and transfer chamber, one pair of natural rubber gloves size 9, two lead-ins for cable on the back side (upper left and upper right). Transfer chamber with two doors, external door with latch to prevent accidentally opening, the tray extends into the workspace with opening of the internal door for easy removal of inserted products.

Cat. No. :	V 1982-08
Overall dimensions* W x H x D mm	1210 x 700 x 600
Add. space requirement for coupling mm	150
Usable interior space W x H x D mm	850 x 500 x 540
Usable volume litres	290
Weight kg, approx.	20
Maximum all-over load kg	40
Opening for gloves mm	ø 190
Distance between opening for gloves mm	390
Hinged lid opening W x H mm	850 x 425
Bore diameter of quick coupling mm	ø 6
Bore diameter in panels mm	ø 16,5
Details transfer chamber:	
Overall dimensions* W x H x D mm	320 x 330 x 260
Usable interior space W x H x D mm	220 x 275 x 320
Usable volume litres, approx.	24
Maximum usable height mm	275 » 1000 ml flask with thread GL 45
Maximum usable width mm	200
Maximum all-over load kg	3



BESTSELLER



SICCO INNOVATION

Cable lead-ins

You can use electronic devices inside your desiccator with the specially designed cable lead-ins.

page 81

«
Special Request?
+49 (0) 93 46-92 86-0
»

Glove Box

»» The large Swing-up door that is to be opened upwards allows a comfortable experiment set-up. It is space saving, this is what has convinced us. ««

Lab assistant catalyst research

SICCO Glove Box

Panels: clear	Material: PMMA	Temperature resistance: -20 °C to +70 °C	Use: normal pressure	Stand: rubber feet
------------------	-------------------	---	-------------------------	-----------------------

Specification:

Aluminium frame with panels made of acrylic glass, base panel made of polyethylene, including hose (5 m) with two quick couplings for gas filling, one pair of natural rubber gloves size 9, two lead-ins for cable on the back side (upper left and upper right).

Cat. No. :	V 1984-08
Overall dimensions* W x H x D mm	890 x 700 x 600
Add. space requirement for coupling mm	150
Usable interior space W x H x D mm	850 x 650 x 540
Capacity liters	290
Weight kg, approx.	14
Maximum all-over load kg	40
Opening for gloves mm	ø 190
Distance between opening for gloves mm	390
Hinged lid opening W x H mm	850 x 425
Bore diameter of quick coupling mm	ø 6 je Durchgang
Bore diameter in panels mm	ø 16,5



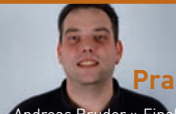

SICCO
Practical Tip

Andreas Bruder » Final quality control

How do you clean the panels correctly?

With a soft cloth and a usual glass cleaner. Do not use solvent containing cleaner with alcohol.

page 78

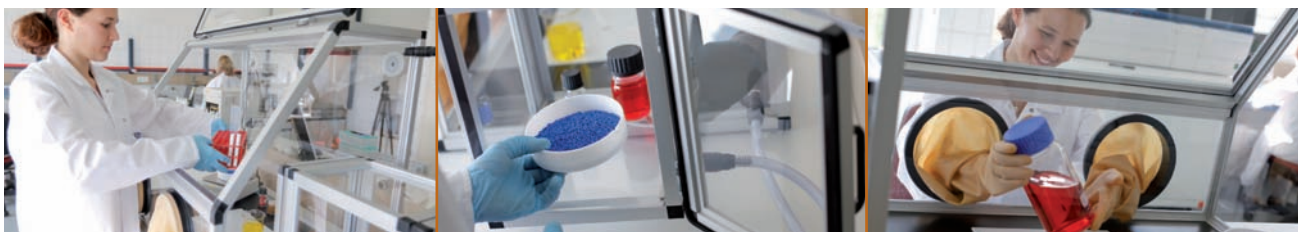

SICCO Glove Box with Transfer Chamber Antistatic

Panels: clear	Material: PC-ESD	Temperature resistance: -20 °C to +70 °C	Use: normal pressure	Stand: rubber feet
-------------------------	----------------------------	--	--------------------------------	------------------------------

Specification:

Aluminium frame with static dissipative panels made of polycarbonate, base panel made of static dissipative polyethylene, including hose (2x 5 m) with four quick couplings for gas filling of workspace and transfer chamber, one pair of static dissipative EPDM gloves size 9,75, two lead-ins for cable on the back side (upper left and upper right). Transfer chamber with two doors, external door with latch to prevent accidentally opening, the tray extends into the workspace with opening of the internal door for easy removal of inserted products. All materials used can discharge electrostatic charging by means of a grounding cable which can be connected on the back side (connecting thread M6).

NEW

Cat. No.:	V 1992-08
Overall dimensions* W x H x D mm	1210 x 700 x 600
Add. space requirement for coupling mm	150
Usable interior space W x H x D mm	850 x 500 x 540
Usable volume litres	290
Weight kg, approx.	20
Maximum all-over load kg	40
Opening for gloves mm	ø 190
Distance between opening for gloves mm	390
Hinged lid opening W x H mm	850 x 425
Bore diameter of quick coupling mm	ø 6
Bore diameter in panels mm	ø 16,5
Details transfer chamber:	
Overall dimensions* W x H x D mm	320 x 330 x 260
Usable interior space W x H x D mm	220 x 275 x 320
Usable volume litres, approx.	24
Maximum usable height mm	275 * 1000 ml flask with thread GL 45
Maximum usable width mm	200
Maximum all-over load kg	3

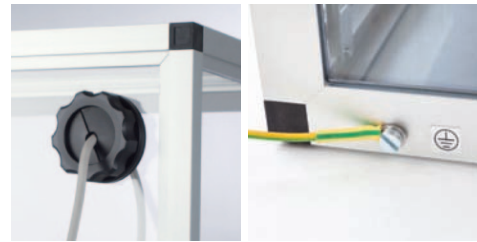
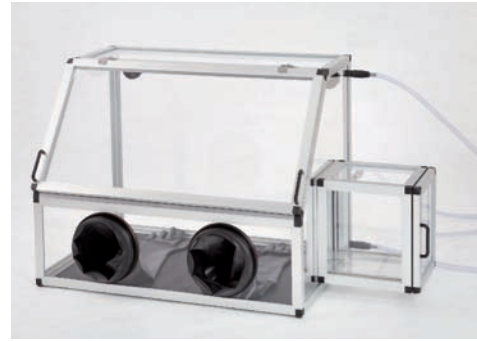

Sonderausführungen möglich!

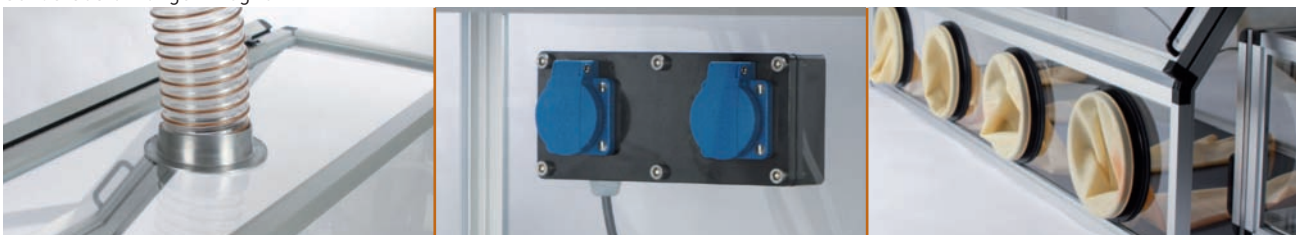

SICCO Extractor Hood

Panels: **clear** Material: **PC/PP** Temperature resistance: **-20 °C to +70 °C**

Specification:

Aluminium frame with panels made of polycarbonate, top panel with integrated connector for exhaust system made of polypropylene.

NEW

Cat.No.:	V 1960-02
Overall dimensions W x H x D mm	900 x 900 x 600
Usable interior space W x H x D mm	860 x 880 x 560
Opening W x H mm	545 x 600
Connector Ø	DN 160
Weight kg. approx.	20

Cat.No.:	V 1960-04
Overall dimensions W x H x D mm	1200 x 900 x 600
Usable interior space W x H x D mm	1160 x 880 x 560
Opening W x H mm	850 x 600
Connector Ø	DN 160
Weight kg. approx.	23

« »
Special Request?
+49 (0) 93 46-92 86-0



SICCO Accessories for desiccators

On the following pages you can find practical accessories which will help you to adapt your SICCO Desiccators to your application.



Increase space for your humidity sensitive products by using additional shelves or drawers.

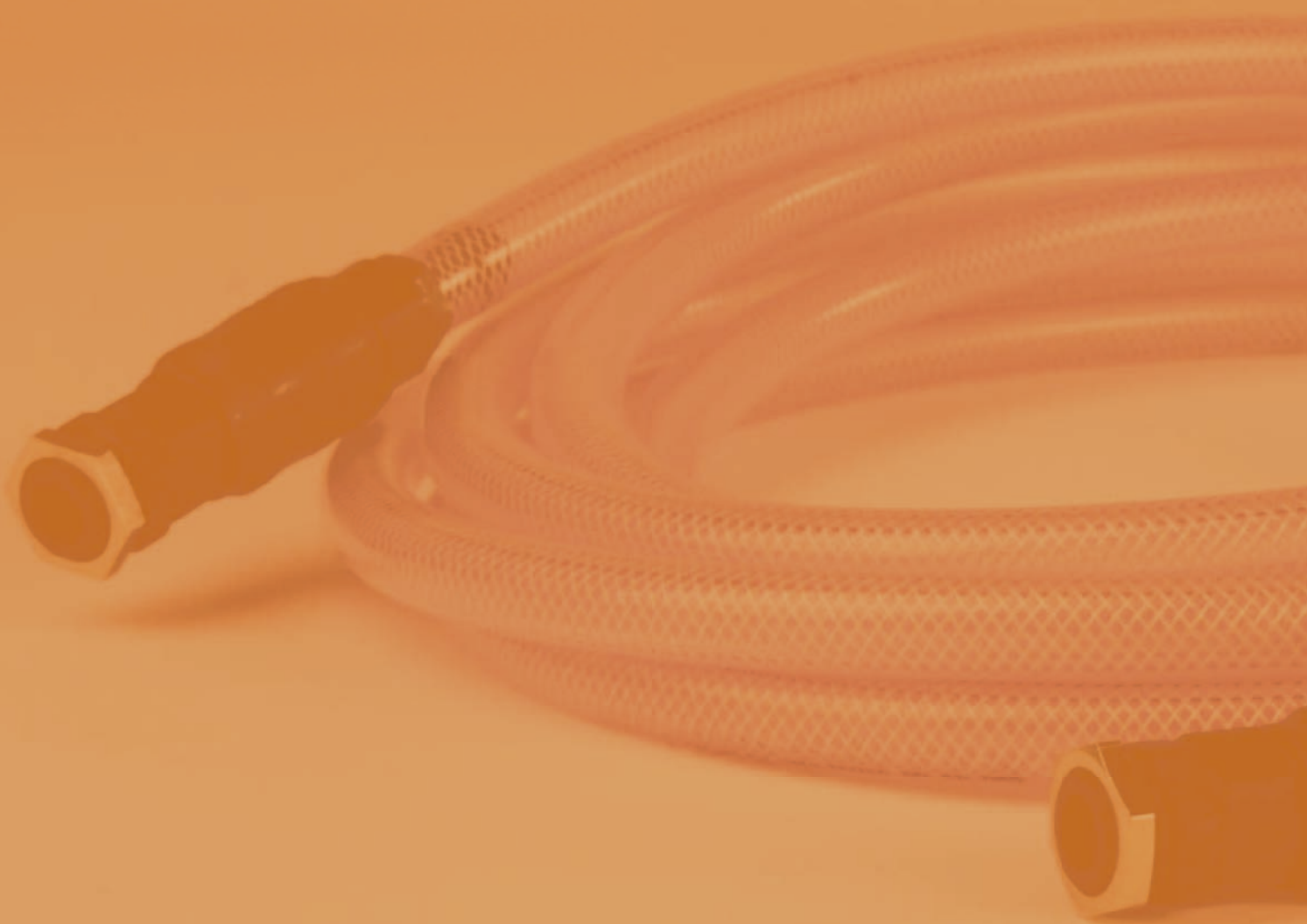

Monitor the exact conditions inside the desiccators with a hygrometer or a humidity-temperature probe with USB-interface.

Hoses, trays, desiccant?
Just take a look at the following pages!

Of course you will receive all this in the usual SICCO high quality.



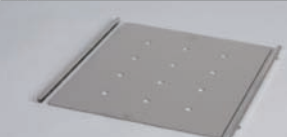



Suitable for:	Product description <i>Dimensions: width x height x depth</i>	Material / Special features	Weight	Cat. No.	
Star, Super-Star, Protect-Star, Auto-Star,	Shelf 258 x 4 x 320 mm; including 2 rails	PMMA, transparent rails made of Polyamide	approx. 420 g including rails	V 1860-68 from unit no. 21117	
	Shelf 258 x 2 x 320 mm; with 12 bores Ø 10 mm including 2 rails	stainless steel, usable up to 150 °C rails made of polyamide	approx. 1.305 g including rails	V 1860-52 from unit no. 21117	
	Collecting tray 235 x 80 x 320 mm max. collecting capacity 1,5 liter including 2 rails	welded stainless steel; max. all-over load: 12 kg; Collecting tray function: 20 mm height rails made of polyamide	approx. 1.200 g including rails	V 1952-16 from unit no. 21117	

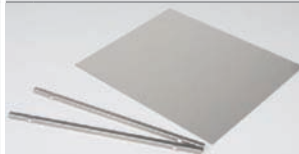

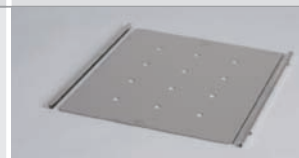
Suitable for:	Product description <i>Dimensions: width x height x depth</i>	Material / Special features	Weight	Cat. No.	
Tower-Star	Shelf 258 x 4 x 320 mm; including 2 rails	PMMA, transparent rails made of aluminium	approx. 420 g including rails	V 1860-67	
	Shelf 258 x 2 x 320 mm; with 12 bores Ø 10 mm including 2 rails	stainless steel, usable up to 150 °C rails made of aluminium	approx. 1.305 g including rails	V 1860-51	
	Collecting tray 235 x 80 x 320 mm max. collecting capacity 1,5 liter including 2 rails	welded stainless steel; max. all-over load: 12 kg; Collecting tray function: 20 mm height rails made of aluminium	approx. 1.200 g including rails	V 1952-08	

Suitable for:	Product description <i>Dimensions: width x height x depth</i>	Material / Special features	Weight	Cat. No.	
Horizontal-Star	Shelf 474 x 4 x 320 mm; including 2 rails	PMMA, transparent rails made of polyamide	approx. 735 g including rails	V 1860-73 from unit no. 21118	

Suitable for:	Product description <i>Dimensions: width x height x depth</i>	Material / Special features	Weight	Cat. No.	
Star Antistatic	Shelf 258 x 2 x 320 mm; including 2 rails	Aluminium	approx. 490 g including rails	V 1860-55	

Suitable for:	Product description <i>Dimensions: width x height x depth</i>	Material / Special features	Weight	Cat. No.	
Vitrum-Star	Shelf 258 x 2 x 320 mm; with 12 bores Ø 10 mm including 2 rails	stainless steel, usable up to 150 °C rails made of aluminium	approx. 1.305 g including rails	V 1860-51	
	Collecting tray 235 x 80 x 320 mm max. collecting capacity 1,5 liter including 2 rails	welded stainless steel; max. all-over load: 12 kg; Collecting tray function: 20 mm height rails made of aluminium	approx. 1.200 g including rails	V 1952-08	



Suitable for:	Product description <i>Dimensions: width x height x depth</i>	Material / Special features	Weight	Cat. No.	
Maxi 1 and 2, Big-Star, Desiccator Wall	Shelf 495 x 0,8 x 515 mm with 36 bores Ø 20 mm including 2 rails	stainless steel, usable up to 150 °C rails made of aluminium	approx. 1.800 g including rails	V 1860-02	
	Collecting tray 472 x 120 x 515 mm including 2 rails max. collecting capacity 3,5 liter	welded stainless steel; max. all-over load: 30 kg; Collecting tray function: 15 mm height	approx. 3.300 g including rails	V 1951-08	
	Collecting tray 472 x 180 x 515 mm including 2 rails max. collecting capacity 4,5 liter	welded stainless steel; max. all-over load: 30 kg; Collecting tray function: 20 mm height	approx. 4.100 g including rails	V 1951-16	

Suitable for:	Product description <i>Dimensions: width x height x depth</i>	Material / Special features	Weight	Cat. No.	
Mini	Shelf 211 x 2,0 x 178 mm	PMMA, transparent	approx. 90 g	V 1860-75	
NEW	Einlegeboden 211 x 4,0 x 178 mm	PE ableitfähig	ca. 149 g	V 1860-77	





Suitable for:	Product description <i>Dimensions: width x height x depth</i>	Material / Special features	Weight	Cat. No.	
Vacuum	Shelf 258 x 5,0 x 250 mm	PMMA, transparent	approx. 380 g	V 1860-30	

Product description <i>Dimensions: width x height x depth</i>	Material / Special features	Weight	Suitable for:	Cat. No.	
Trays					
NEW 247 x 30 x 297 mm für 1000 g Silicagel	PBTP	365 g	for all Desiccators	V 1861-07	

Desiccant					
Silica gel with colour indicator from orange to dark brown and black, (does not contain cobalt-II- chloride)	Grain size 2,0–5,0 mm, loss after drying < = 4 %	360 g 720 g		V 1895-04 V 1895-08	
Desiccant Cartridge Aluminium cartridge with encapsulated silica gel, saturation is displayed on the top side by colour indicator from blue to pink.	width x height x depth 102 x 12 x 53 mm	40 g	Mini and Star-Desiccators,	V 1901-04	
Desiccant Cylinder Aluminium cylinder with encapsulated silica gel, saturation is displayed on the top side by colour indicator from blue to pink.	height x diameter 136 x 108 mm	750 g	for all Desiccators	V 1902-04	

Product description <i>Dimensions: width x height x depth</i>	Material / Special features	Weight	Suitable for:	Cat. No.	
Silica gel with colour indicator from orange to dark brown and black, regenerative (does not contain cobalt-II- chloride)height x diametre 45 x 41 mm	Grain size 2,0-5,0 mm, loss after drying <= 4 %	23 g	Mini-Desiccators	V 1903-04	
PVC hose for introduction of gas, including two quick couplings made of POM and non-return valve.	PVC Fibre hose I.D. 9 mm x O.D. 15 mm	5 m Length	Desiccators for gas-filling	V 1864-01	



Hygrometers



Electr. Thermo-Hygrometer with max-min function; 52 x 15 x 39 mm; including LR 44 button cell, fastener and fastening screws	Measuring ranges: Temperature: -10 to +60 °C Humidity: 10-99 % r.h.. Max. measuring error: ± 1 °C at -10 to +50 °C ± 5 % r.h. at 25-75 % r.h. and 0-50 °C	30 g	Star-Desiccators Maxi-Desiccators	V 1863-07	
Electr. Thermo-Hygrometer with max-min function; 52 x 15 x 39 mm; including LR 44 button cell, fastener and fastening screws	Measuring ranges: Temperature: -10 to +60 °C Humidity: 10-99 % r.h.. Max. measuring error: ± 1 °C at -10 to +50 °C ± 5 % r.h. at 25-75 % r.h. and 0-50 °C	30 g	Mini Desiccators	V 1863-05	
Electr. Thermo-Hygrometer with max-min function, large display; 110 x 20 x 95 mm; including battery 1,5 V AAA, fastening material	Measuring ranges: Temperature: -10 to +60 °C Humidity: 10-99 % r.h.. Max. measuring error: ± 1 °C at -10 to +50 °C ± 5 % r.h. at 25-75 % r.h. and 0-50 °C	171 g	Star-Desiccators, Maxi Desiccators	V 1866-07	
Electr. Thermo-Hygrometer with max-min function, 120 x 40 x 89 mm; including battery, calibration report resolution 0.1% r.h. / 0.1 °C, measuring cycle 18 seconds	Measuring ranges: Temperature: -10 to +70 °C, ± 0,5 °C Humidity: +2 to 98 % rh, ± 2 % Dew point: -40 to +70 °C td Durability: 8736 h	168 g	Star-Desiccators, Maxi Desiccators	V 1859-08	

NEW

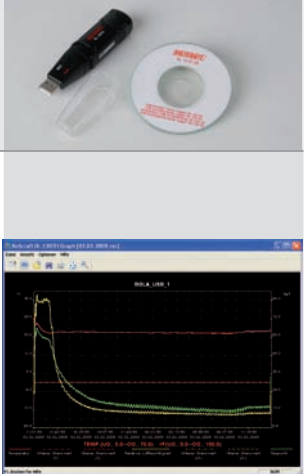
Mini Hygrometer for constant measurement of humidity and temperature, two-digit LED display for temperature and humidity measurement at the same time.

68 x 45 x 25 mm; Digital LED display, including two batteries 1,5 V AAA	Measuring ranges: Temperature: 0 to +50 °C Humidity: 1 - 99% rh Max. measuring error: ± 1 °C at 25°C ± 3% rh at 1% - 80% Resolution: 1% rF / 1 °C Sensor drift: 1% rh and 0,2 °C in 4 years	65 g	for all Desiccators	V 1829-08	
--	---	------	------------------------	-----------	---

Product description <i>Dimensions: width x height x depth</i>	Material / Special features	Weight	Suitable for:	Cat. No.	
Humidity-Temperature Probe with USB-Interface					
<p>Combined temperature and humidity probe which can be directly driven by a PC by means of USB interface in handle, wide measuring range, high resolution, very good linearity and durability, calculation and indication of dew point, absolute humidity, vapor pressure, saturated vapor pressure and enthalpy, tabulated measured values, data are recorded on hard disk, humidity is measured with a long-term stable, capacitive polymer sensor, for monitoring store rooms in food production industry, quality control or HVAC technology, humidity measuring systems for custom projects, microcontroller applications, for Windows or Linux</p>					
<p>Combined temperature and humidity probe,</p> <p>including carry case and Windows-software for measured value display and data recording as well as USB plug type A, 1.1 or 2.0 compatible</p>	<p>Dim. of stainless steel tube Ø 12 x 125 mm and sintering filter,</p> <p>Measuring range: 0-100% rh, ± 2 % and -40 to 80 °C, ± 0,5 K Humidity: 0,01% rh Temperature: 0,01 K</p>	100 g	Star Desiccators Maxi Desiccators	V 1868-08	
USB-Datalogger					
<p>Compact data logger with built-in lithium battery for recording temperature and humidity. The stored data can be read out via USB interface and charted with the included software or exported for further processing with other programs (e.g. Excel). For recording of 16.000 measurements of temperature and humidity.</p>					
<p>130 x 30 x 25 mm Reacting frequency: 2 / 5 / 10 / 30 seconds, 1 / 5 / 10 / 30 minutes, 1 / 2 / 3 / 6 / 12 / 24 hours</p> <p>software for Windows 98/2000/XP/Vista, lithium battery (lifespan approx. 1 year for recording intervals of 5 sec or 2.5 years for intervals of 10 sec), wall bracket, operating instructions on CD</p>	<p>Measuring ranges: Temperature: -40 to +70 °C, ± 1 °C Response time approx. 20 s</p> <p>Relative humidity: 0-100 % RH, ± 3 % Response time approx. 5 s</p> <p>Accuracy of dew point (at 25 °C and 40-100 % RH): ± 2 °C Resolution: 0.1 °C / 0.1 % RH</p>	20 g	Star Desiccators Maxi Desiccators	V 1869-08	
Gloves					
<p>Mutually wearable; suitable for holes of Ø 190 mm perforation- and abrasion-proof, high flexibility, low voltage value; low electrostatic charging, Length 750 mm Natural rubber</p>	Size 7			V 1972-07	
	Size 8			V 1972-08	
	Size 9			V 1972-09	
<p>Mutually wearable; suitable for holes of Ø 190 mm perforation- and abrasion-proof, high flexibility, low voltage value; electroconductive 10⁵ ohm, Length 800 mm EPDM conductive, black</p>	Size 9,75			V 1974-09	

Suitable for:	Product description Dimensions: width x height x depth	Material / Special features	Weight	Cat. No.	
Connectors for Desiccators					
NEW For safe and fix connection of stacked SICCO Desiccators without boring.					
Star-Desiccators (except Thermo-Star)	Connectors for Desiccators (20 x 60 x 10 mm) consisting of four pairs of braces, each pair with one screw and nut, one hexagon wrench, operating instruction	Aluminium	approx. 100 g	V 1953-07	
Big-Star-Desiccators Maxi-Desiccators	Connectors for Desiccators (20 x 60 x 10 mm) consisting of four pairs of braces, each pair with one screw and nut, four silicone o-rings, one hexagon wrench, operating instruction	Aluminium Rubber feet and casters have to be disassembled from the upper desiccator. The provided silicone o-rings avoid a slipping of the desiccators.	approx. 110 g	V 1954-07	





- » Cleaning
- » Assembly of shelves
- » Efficient use of Silica Gel
- » Optimise drying efficiency
- » Safe assembly of cables
- » Materials

Performance at a glance.

DRYING PERFORMANCE Desiccators for drying/storage

Test procedure:

A relative humidity of approx. 100 % is simulated in a desiccator. In the bottom of the desiccator there is a tray with 500 g of silica gel. The door is closed and is airtight. The curves show relative humidity versus time.

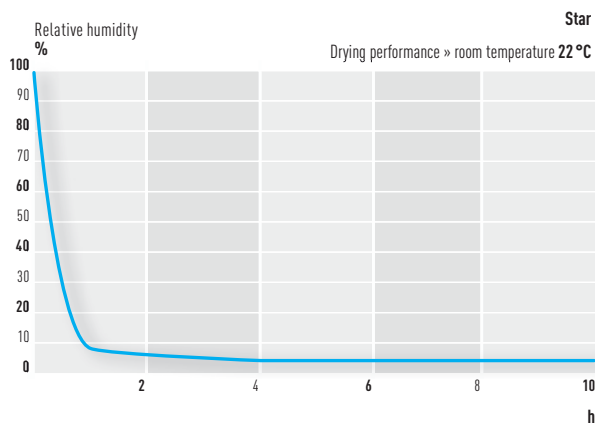

Relative humidity of below 10 % after approx. one hour.

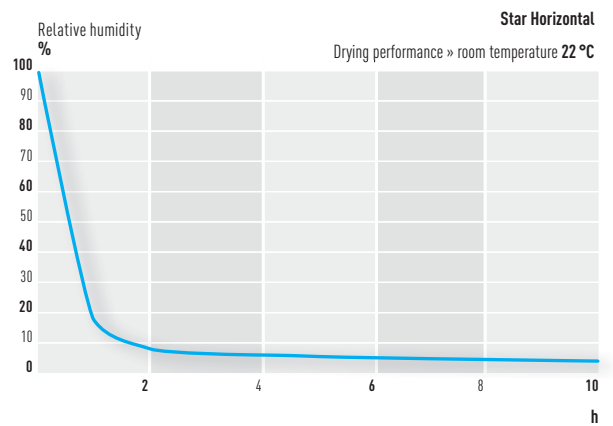

Relative humidity of below 10 % after almost two hours.

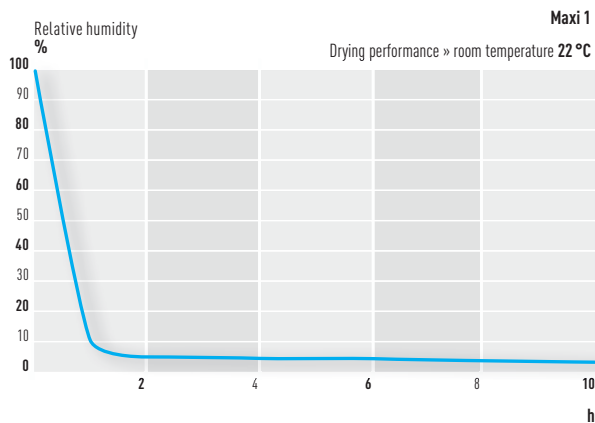

Relative humidity of below 10 % after little more than one hour.

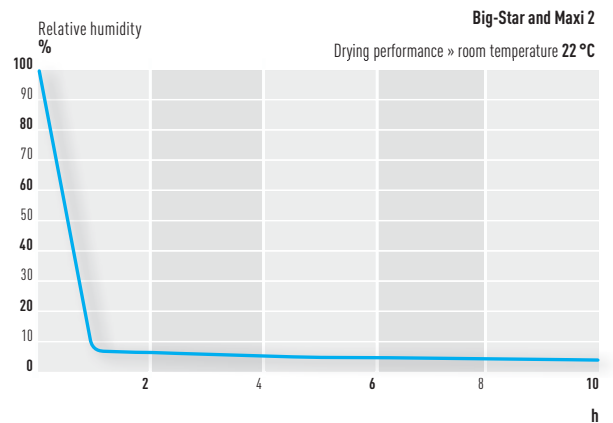

Relative humidity of below 10 % after approx. one hour.

OPENING AND CLOSING THE DOOR

Test procedure:

A desiccator with three shelves is loaded with approx. 30 beakers. A relative humidity of max. 7% is maintained inside the desiccator. On one shelf and at the bottom of the desiccator there is one tray (350 x 240 mm) with 500 g of silica gel.

Then the airtight door is opened for 10 seconds and then closed. The curves show the development of humidity.

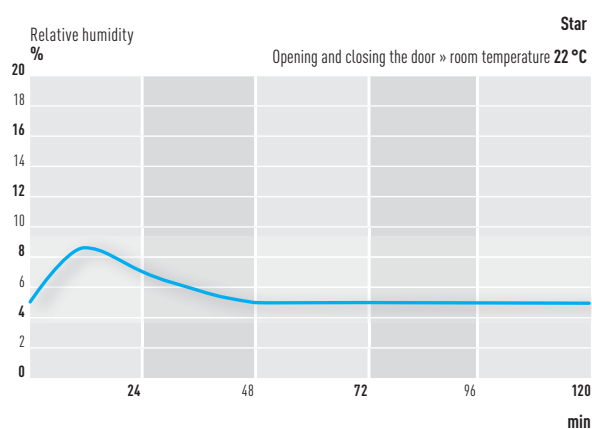

The initial value is attained after approx. 48 minutes.

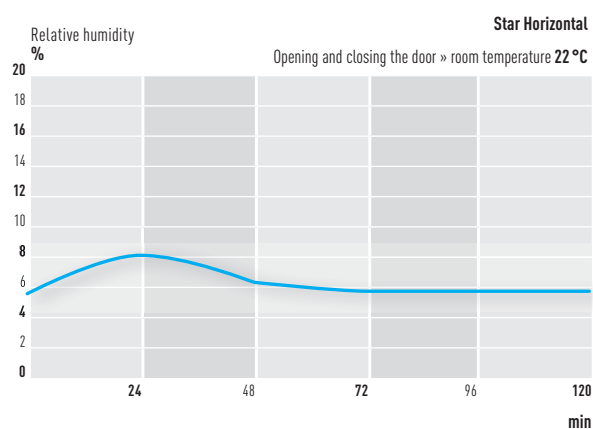

The initial value is attained after approx. 58 minutes.

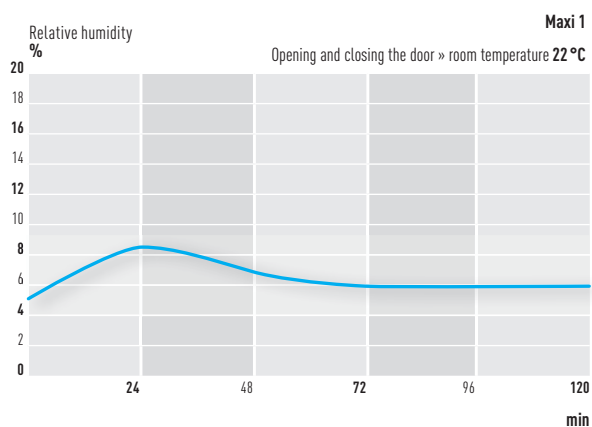

The initial value is attained after approx. 72 minutes.

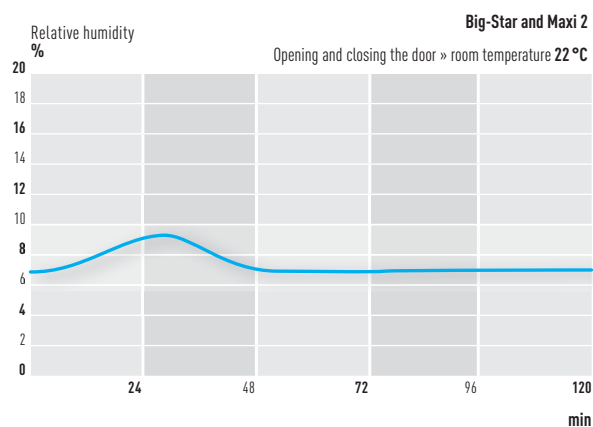

The initial value is attained after approx. 48 minutes.

Performance at a glance.

DRYING PERFORMANCE Automatic-Desiccators

Test procedure:

After a pre drying period of 10 minutes, a humidity of 100 % is simulated in an Automatic-Desiccator. The desiccator is switched on, the door remains closed tightly until the end of the test. The curves show relative humidity versus time.

Results:

After only 10 hours, the relative humidity inside the desiccator is down to 10 % due to automatic drying. Frequent controls are not necessary. The storage space is bigger since it is not necessary to use silica gel and process errors are avoided.

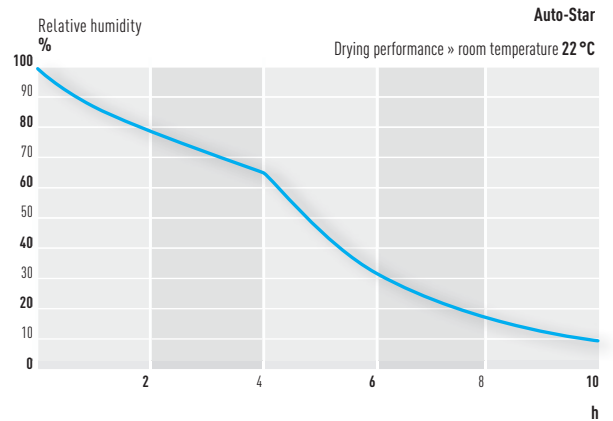

Relative humidity of below 30 % after little more than 6 hours

OPENING AND CLOSING THE DOOR

Test procedure:

An Automatic-Desiccator with three shelves is loaded with six bottles of 1.5 litres capacity on the two lower shelves. In addition, there are 12 beakers on the upper shelf. A relative humidity of 13% is produced in the desiccator. The airtight door is opened for 10 seconds and closed. The curves show the relative humidity versus time.

Results:

The humidity falls to the initial value of 13 % after a short period of time. Application errors that may occur with silica gel are avoided.

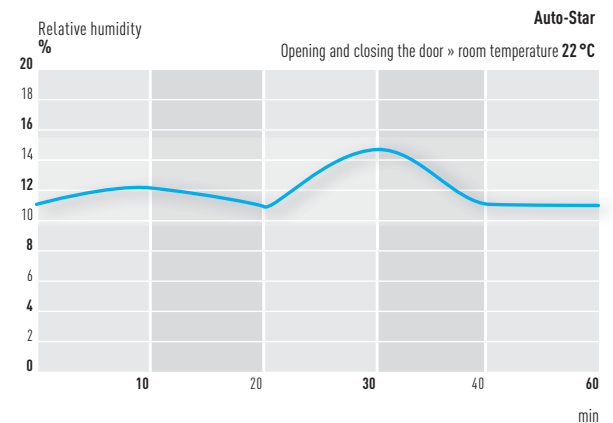

The initial value is attained after approx. 40 minutes.

INTERRUPTION OF POWER SUPPLY

Test procedure:

An Automatic-Desiccator with three shelves is loaded with six bottles of 1.5 litres capacity on the two lower shelves. In addition, there are 12 beakers on the upper shelf. A relative humidity of 13 % is produced in the desiccator. Then the desiccator is switched off at a room temperature of 22 °C. The curves show relative humidity versus time.

Results:

A significant increase of humidity is only noticeable after several hours. This means that the contents of the desiccator remain safe even if the power supply is interrupted.

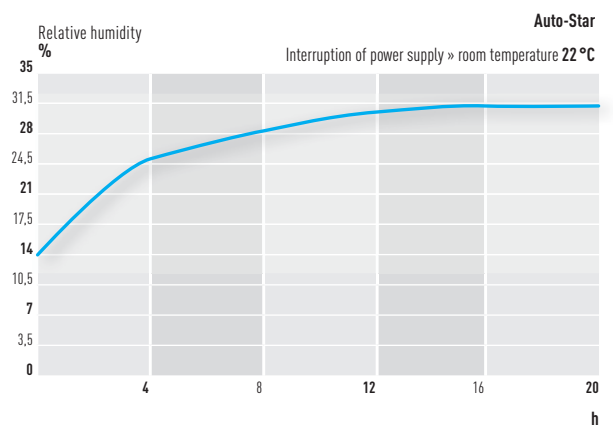

Only 15 % of increase within 20 hours.

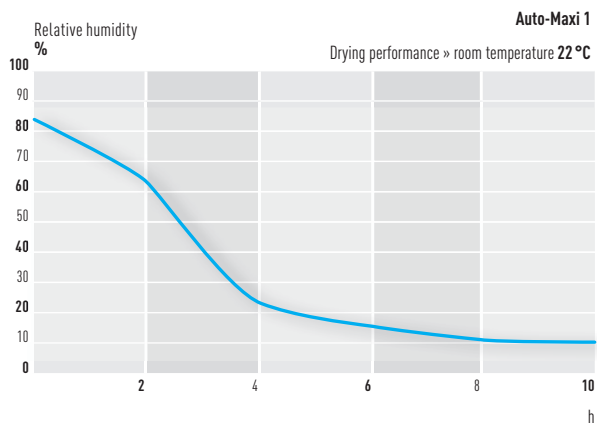

Relative humidity of below 30 % after little more than 3,5 hours.

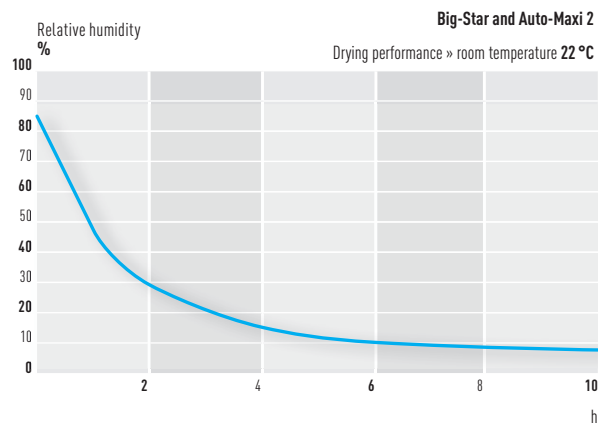

Relative humidity of below 30 % after approx. 2 hours

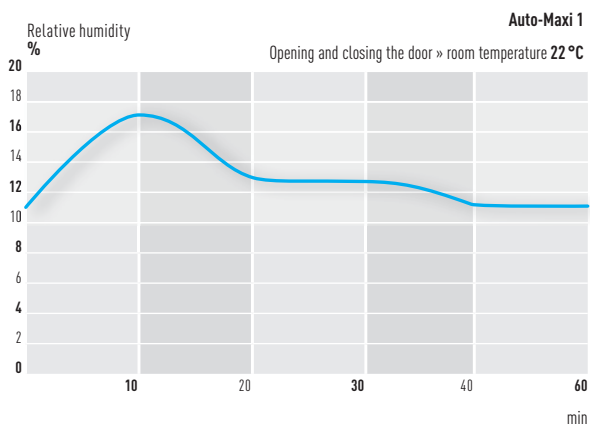

The initial value is attained after approx. 40 minutes

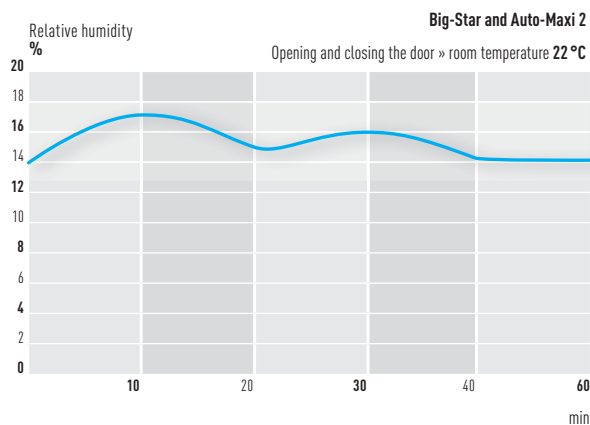

The initial value is attained after approx. 40 minutes

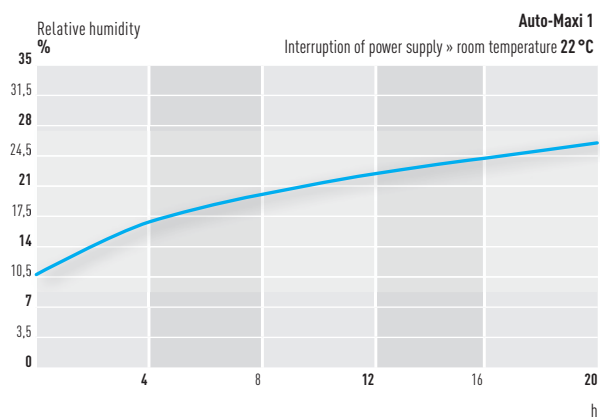

Only 18 % of increase within 20 hours

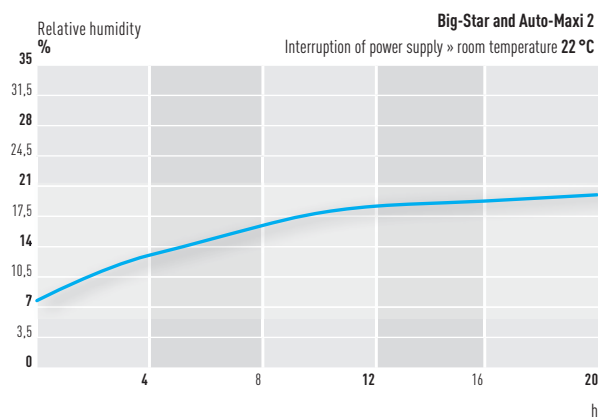

Only 15 % of increase within 20 hours.

Cleaning of Desiccators

For the correct cleaning, use a soft cloth or a sponge (no microfiber) so that the panels will not get scratches. Glass cleaner or pH-neutral cleaner have proved its worth. There are also special antistatic plastic cleaner and caring products that avoid the electric static charging of the panels. Thereby less dust and floating particles are energized. Do not use cleaner with acetone, benzol or carbon tetrachloride. These substances damage the surface by softening or blurring it.



Suspension arrangements and Rails

With the numbered suspension arrangements and rails of the SICCO Star Desiccators you can easily and quickly position your shelves. You will not have to test until the shelves have found their horizontal position. The consecutive numeration on the rail system helps in addition for the documentation of your experiment.



Safe stacking of desiccators

SICCO Connectors for Desiccators allow a fix connection of stacked drying cabinets. On each side, two braces will be clipped on the front and back part of the frame and safely fixed by a hexagonal screw. For the assembly of Big-Star and Maxi-Desiccators, the rubber feet and casters of the upper unit have to be removed. A slipping of the stacked units is prevented by additional o-rings made of silicone. Due to its construction, the connectors can be mounted later at any time without additional boring.



Proper use of desiccant

The humidity in your desiccator can be reduced most rapidly if you spread it on a big surface. The provided desiccant tray is best suitable for it. Please make sure that the desiccant surface is not higher than one centimeter. If you have to increase the desiccant quantity for your experiment, please take another tray.

Up to 16 g humidity can be absorbed by the SICCO desiccant within 24 hours.



Regeneration of Silica Gel

Silica Gel has a color-indicator that shows the rate of saturation of the desiccant. Orange means dried and absorptive, dark brown to black means saturated. To regenerate the desiccant, put it into the oven at 90-110°C together with the provided tray for 90 minutes. A microwave is unsuitable for this. You have to calculate 90 minutes for regeneration per centimeter filling height. Overheated desiccant is destroyed and cannot be regenerated. Please store the not required Silica Gel in an hermetically sealed jar.



Reduction of humidity

In the desiccators without automatic drying, the reduction of humidity occurs through the inserting of Silica Gel. This desiccant has the property to bind humidity from the environment. If the desiccant is saturated, it can be regenerated. If humidity does not decrease as required, the Silica Gel is already saturated or too less Silica Gel is used. Increase the portion. Check if the door closes correctly or if the sealing is damaged. Check if the hygrometer is working by comparing it with another one. Insert a new battery.



Faster decrease of humidity in your desiccator

You can put a little ventilator inside your desiccator for a better air circulation and thus a faster decrease of humidity. It can be driven by solar cells or a cable to an external power source. Normally, the cable of a transformer is thin enough to be lead into the desiccator through the sealing at the hinge side. Thick cables can be put in without difficulty because of the SICCO cable lead-in. The cable lead-in can be installed in a new desiccator.



Reduction of air exchange

When opening the door of the desiccator, the humid air from the environment intermixes with the dry air in the desiccator. In order to keep the air exchange as low as possible, form an artificial wall by putting large vessels in the front part of the desiccator. This barrier distracts the incoming air. In case of empty shelves, you can additionally glue a paper or a film in the gaps and thus reduce the circulation of air.



The SICCO cable lead-in

You can use electronic devices inside your desiccator with the specially designed cable lead-ins. The cable lead-in allows the complete cable to be pulled through the desiccator wall; there is no need to detach the plug. Multi-core and flat cables with a diameter between 0,1 and 10 mm are fixed and sealed safely.



Tip: Even tubes with hard walls can be inserted and sealed tightly.



round power cable with plug

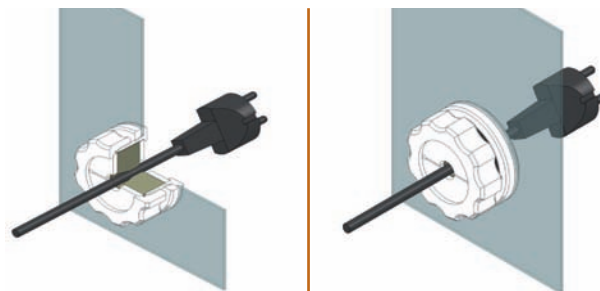

bipolar power cable with SMP plug

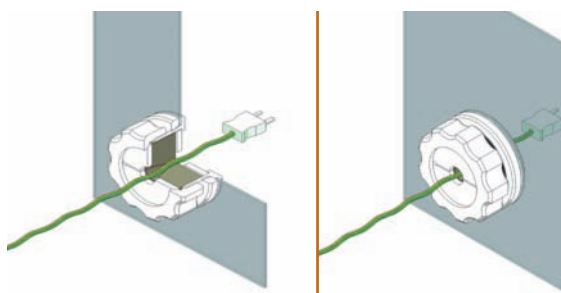



Robust construction, appealing design, sophisticated functionality: SICCO desiccators and drying cabinets leave nothing to be desired. That's BOHLENDER experience and know how gained from more than 30 years of delivering safe storage systems for sensitive items and materials.

We have always set high quality standards; all design, development and manufacturing are done in house by BOHLENDER professionals.

SICCO – built for those who expect more.

Extra flexibility

Depending on the kind of material, the quantity and how long you would like to store it, your requirements for a desiccator or a drying cabinet may change. Your needs set our benchmarks. Having design and production in house makes it possible efficiently to meet your requirements. We are sure you will find a suitable desiccator in our extensive product range. If not we can make custom units; we need a brief specification and our design department will start work to meet all your requirements.

Extra expertise

We listen to our customers! Desiccators and drying cabinets are part of Bohlender's product range since 1977. And since 1998, we have been manufacturing them in house. Based on your feedback, our products are continuously improved and adapted to meet your requirements. Should you have any questions or requests, our professional staff will give you expert advice. Who knows more about drying cabinets and desiccators than the manufacturer?



Extra service

Some enquiries are urgent. To meet customer needs we keep the majority of our products in stock. Our efficient, well-established workflow systems assure rapid shipment of your order whether it is for desiccators, drying cabinets or accessories. Waiting times and unnecessary downtime can be prevented. You have no time to lose? We are here to help.

Extra reliability

Valuable items or sensitive substances require reliable and safe storage. SICCO desiccators and drying cabinets are consistently designed and built for security and longevity. We use solid, shock resistant aluminium frames and high-quality, unbreakable acrylic panels which optionally are available either as antistatic or UV radiation resistant. Consistent, high quality inhouse manufacturing by our highly qualified staff complement a comprehensive quality assurance system. This results in desiccators and drying cabinets which are top of the class.

Extra features

Our goal is that you are completely satisfied using our products just as we enjoy developing and producing them.

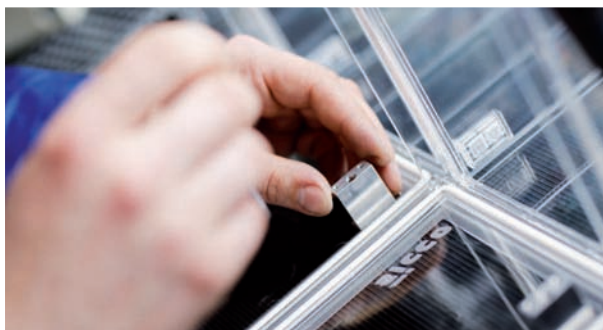

The special appeal of SICCO desiccators and drying cabinets stems from the many well-thought details and unique features such as our innovative, magnetic locking system "One-Touch-Door". The door closes tightly but can easily be opened and closed with a light touch.

SICCO Materials

PMMA

coll: acrylic glass
 also known under the tradename
 Plexiglas® of company
 Evonik Röhm GmbH
 Synthetic, thermoplastic material;
 Break proof and impact resistant;
 Very good surface, shiny; Good resistance
 to dilute acids and alkali, limited
 resistance to organic solvents; Flammable
 properties similar to hardwood;
 Very low production of smoke if burnt;
 Gases emitted when burning are neither
 toxic nor corrosive;
 Usable up to approx. +70 °C
 Volume resistivity: >10¹⁵ Ω/cm,
 test specification DIN VDE 0303,
 Surface resistivity: 5 x 10¹³ Ω,
 test specification DIN VDE 0303, part 3;
 Transmittance tD65: ~92 %,
 test specification DIN 5036, part 3

PMMA orange

Properties: see above;
 tD65 = transmittance according to
 DIN 5036 at standard illuminant D65
 (daylight, approx 6500 K, DIN 5033): 42 %
 aD65 = absorbance according to
 DIN 5036: 52 %

PC

Polycarbonates are plastics that belong
 to the group of synthetic polymers and to
 the family of polyesters. Polycarbonates
 are transparent and non-coloured but they
 can easily be coloured. The material is
 characterized by its high stability, impact
 resistance, stiffness as well as its rigi-
 dity. Polycarbonates are widely resistant
 against atmospheric conditions and radi-
 ation. They're flammable but can easily
 be extinguished by erasing the source
 of ignition. Moreover polycarbonates are
 good isolators. They're water resistant,
 resistant against many mineral acids and
 hydrous solutions of neutral salts and
 oxidants. Also some other non-polar orga-

nic solvents like carbon hydride and many
 oils and fat do not cause any damage to
 polycarbonates. However polycarbonates
 aren't resistant against chlorinated
 carbon hydrides, e.g. dichloromethane. It
 is also instable against hydrous alkaline
 solutions, amines and ammonia.

Polycarbonate

PC-ESD is made of transparent, two side
 coated permanent static dissipative
 material. The dissipative property reduces
 particle attraction and the generation of
 electrostatic fields. Complies with
 EN 61340-5-1 and ANSI/ESD S20.20-1999

Borosilicate glass

is crystal-clear, non-coloured and shows
 no significant absorption in the visible
 spectrum. The permeability of ultraviolet
 radiation allows it to use the products for
 photochemical reactions. The refraction
 index is at 1,472 (with 589,3 nm) and the
 photoelastic constant is B 3,6 10⁻⁶ MPa-
 1. The physical properties of borosilicate
 glass are described in norm DIN ISO 3585.
 Borosilicate glass has a high chemical
 resistance against alcohols, water and
 acids and their mixtures, as well as
 chlorine, iodine, bromine. The interaction
 of water only has a small effect on the
 glass. A thin layer of fused quartz is built
 up which reduces a further attack on the
 glass.

Water resistance (ISO 719)

Water classification 1

Acid resistance (ISO 1776)

Acid classification 1-2

Alcali resistance (ISO 695)

Alcali classification 2

Relative humidity

Percentage ratio between water vapor
 pressure and saturated water vapor pres-
 sure over a clear and even water surface.
 On this basis it is easy to evaluate how
 quickly evaporation will proceed or how
 large is the danger of condensation. The
 quantity of water vapor which would be
 needed for saturation increases with
 increasing temperature. Similarly the
 relative humidity of a given air mass falls
 with increasing temperature. Temperature
 is therefore an important factor in asses-
 sing relative humidity and condensation

Silica gel

Silica gel is a colourless amorphous
 silicic acid with a gel-like consistency. It
 has a large inner surface area. It is very
 hygroscopic and can be used as gelling
 agent, filtering or absorption material
 and desiccant. Normally coupled with an
 indicator, silica gel changes colour as
 soon as it absorbs water; the gel remains
 pourable and dimensionally stable even in
 saturated condition. It can be regenerated
 on a metallic sieve or on a baking tray at
 approx. 90-110 °C (a microwave oven is
 not suitable for regeneration!).

Dew point

The dew point is the temperature at which
 water vapour starts to condense.

Numerical Index

Artikel	Seite	Artikel	Seite
V 1830-07	17	V 1901-04	68
V 1840-06	35	V 1902-04	68
V 1841-07	25	V 1903-04	69
V 1842-06	30	V 1910-07	50
V 1843-06	52	V 1914-01	46
V 1844-07	26	V 1916-01	47
V 1845-07	27	V 1922-07	51
V 1846-07	26	V 1923-07	51
V 1847-06	20	V 1925-07	50
V 1848-06	21	V 1926-07	29
V 1849-06	42	V 1927-07	29
V 1850-01	18	V 1928-07	30
V 1850-02	18	V 1932-01	40
V 1850-03	18	V 1933-01	41
V 1852-01	14	V 1935-07	39
V 1853-01	15	V 1936-07	33
V 1859-08	69	V 1937-07	34
V 1860-02	67	V 1938-07	13
V 1860-30	68	V 1939-07	33
V 1860-51	66 / 67	V 1940-06	35
V 1860-52	66	V 1942-06	31
V 1860-55	67	V 1943-06	52
V 1860-67	66	V 1947-06	20
V 1860-68	66	V 1948-06	21
V 1860-72	66	V 1949-06	42
V 1860-73	66	V 1950-01	19
V 1860-75	68	V 1950-02	19
V 1860-77	68	V 1950-03	19
V 1861-07	68	V 1951-08	67
V 1863-05	69	V 1951-16	67
V 1863-07	69	V 1952-08	66 / 67
V 1864-01	69	V 1952-16	66
V 1866-07	69	V 1953-07	71
V 1868-08	70	V 1954-07	71
V 1869-08	70	V 1960-02	64
V 1871-07	12	V 1960-04	64
V 1875-07	38	V 1972-07	70
V 1877-07	45	V 1972-08	70
V 1879-07	28	V 1972-09	70
V 1880-04	56	V 1974-09	70
V 1880-08	57	V 1982-08	61
V 1880-12	57	V 1984-08	62
V 1891-07	32	V 1992-08	63
V 1894-07	46	V 1994-08	24
V 1895-04	68	V 1995-08	48
V 1895-08	68	V 1997-08	53
V 1896-07	14		
V 1899-07	13		

Alphabetical Index

A

Accessories	65 - 71
Antistatic-Desiccators	49 - 53
Auto-Big-Star-Desiccator	46
Auto-Desiccator Wall	48
Automatic-Desiccators	43 - 48
Auto-Maxi 1-Desiccator	46
Auto-Maxi 2-Desiccator	47
Auto-Star-Desiccator	45

B

Big-Star-Desiccator	14
Big-Star-Desiccator Antistatic	50
Big-Star-Desiccator Black	33
Big-Star-Desiccator Protect	29
Big-Star-Vitrum-Desiccator	26

C

Collecting tray for Maxi 1 and 2, Big-Star	67
Collecting tray for Star-Desiccators	66
Conductive Desiccators	49 - 53
Conductive Gloves	70
Connectors for Desiccators	71
Connectors for gas-filling	69

D

Desiccant Cartridge	68
Desiccant Cylinder	68
Desiccators for drying/storage	11 - 35
Desiccators for gas-filling	37 - 42
Desiccators of glass	25 - 27
Desiccator Wall	24
Desiccator Wall Antistati	53
Desiccators with earthing connection	49 - 53

E

Extractor Hood	64
----------------	----

G

Glove Box	62
Glove Box with Transfer Chamber	61
Glove Box with Transfer Chamber Antistatic	63
Gloves	70
Gloves Antistatic	70
Grounded Desiccators	49 - 53

H

Heated Desiccators	17
Humidity-Temperature Probe with USB-Interface	70
Hygrometer	69

L

Light-protected Desiccators	28 - 35
Lockable Desiccators	20 / 38

M

Maxi 1-Desiccator	14
Maxi 1-Desiccator Antistatic	51
Maxi 1-Desiccator Black	33
Maxi 1-Desiccator Protect	29
Maxi 1-Vitrum-Desiccator	26
Maxi 2-Desiccator	15
Maxi 2-Desiccator Antistatic	51
Maxi 2-Desiccator Black	34
Maxi 2-Desiccator Protect	30
Maxi 2-Vitrum-Desiccator	27
Mini 1-Desiccator Basic	18
Mini 1-Desiccator Premium	19
Mini 2-Desiccator Basic	18
Mini 2-Desiccator Premium	19
Mini 3-Desiccator Basic	18
Mini 3-Desiccator Premium	19
Mini-Desiccator Antistatic Basic	52
Mini-Desiccator Antistatic Premium	52
Mini-Desiccator Black Basic	35
Mini-Desiccator Black Premium	35
Mini-Desiccator for Gas-Filling Basic	42
Mini-Desiccator for Gas-Filling Premium	42
Mini-Desiccator Protect Basic	30
Mini-Desiccator Protect Premium	31
Mini-Desiccator Secure Box Basic	20
Mini-Desiccator Secure Box Premium	20
Mini-Mobile-Desiccator Basic	21
Mini-Mobile-Desiccator Premium	21
Mobile Desiccators	21

P

Portable Desiccators	21
----------------------	----

S	
Shelf for Maxi 1 and 2, Big-Star	67
Shelf for Mini-Desiccator	68
Shelf for Star-Desiccator Antistatic	67
Shelf for Star-Desiccator Horizontal	66
Shelf for Star-Desiccators	66
Shelf for Vacuum-Desiccator	68
Silicagel	68 - 69
Star-Desiccator	12
Star-Desiccator Antistatic	50
Star-Desiccator Black	32
Star-Desiccator Horizontal	13
Star-Desiccator Protect	28
Star-Thermo-Desiccator	17
Star-Vitrum-Desiccator	25
Super-Big-Star-Desiccator	39
Super-Maxi 1-Desiccator	40
Super-Maxi 2-Desiccator	41
Super-Star-Desiccator	38
T	
Temperature adjustable Desiccators	17
Temperature-Humidity Probe with USB-Connector	70
Tower-Star-Desiccator	13
Tray for Silicagel	68
U	
USB-Datalogger	70
V	
Vacuum 1-Desiccator	56
Vacuum 2-Desiccator	57
Vacuum 3-Desiccator	57
Vacuum-Desiccators	55 - 57



SICCO

A PRODUCT BRAND OF
BOHLENDER GmbH
Waltersberg 8
D 97947 Grünsfeld
Germany

Phone: +49 (0) 93 46 - 92 86-0
Fax: +49 (0) 93 46 - 92 86-51
Mail: info@sicco.de
www.sicco.de



MANEKO, spol. s r. o.
Na Pískách 71
16000 Praha 6
www.maneke.cz
maneko@maneko.cz
TEL: 23333 5638-9
FAX: 23333 2656